

REHABILITATION

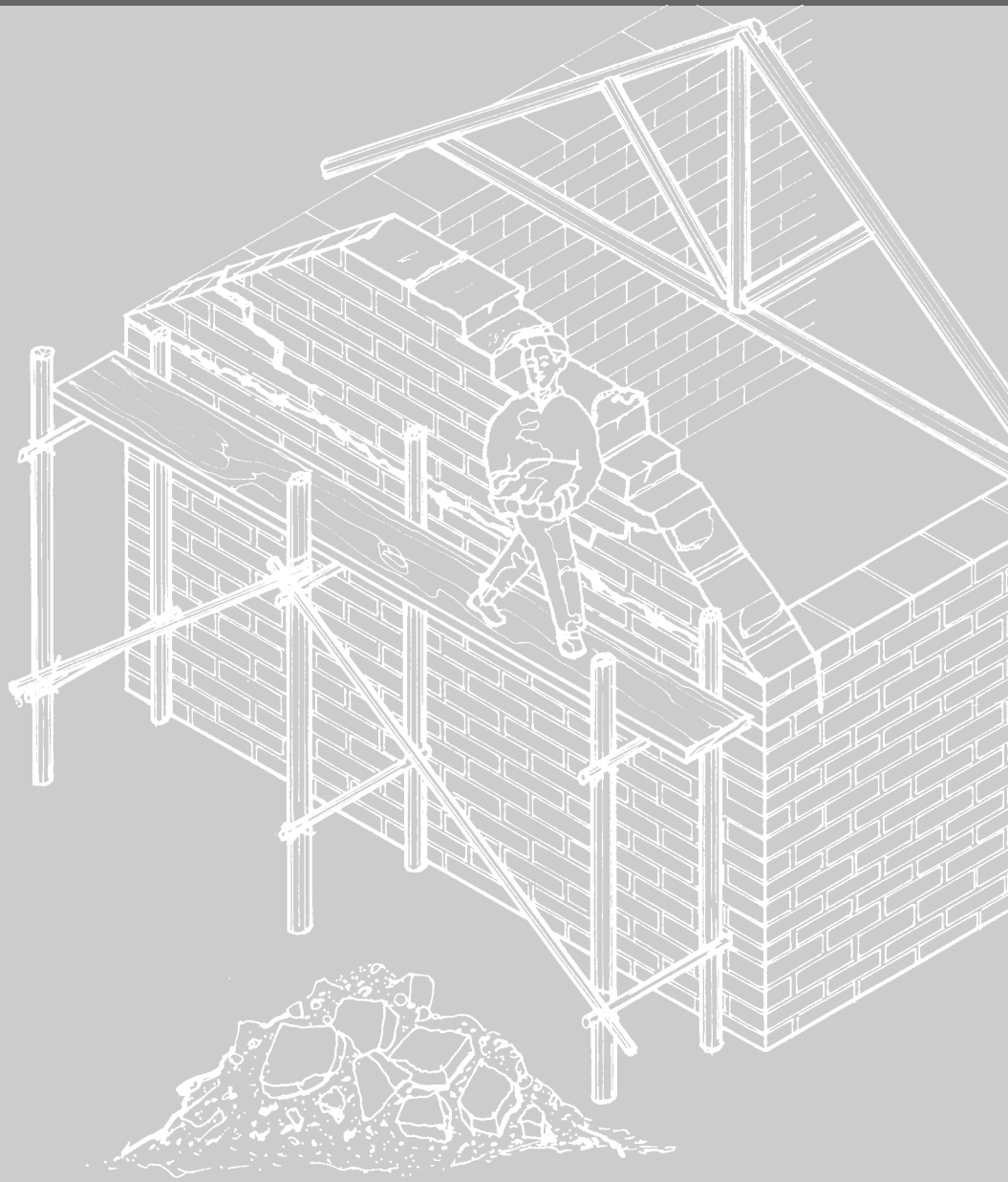

Anti-seismic construction handbook

Arch. Wilfredo Carazas Aedo
Arch. Alba Rivero Olmos

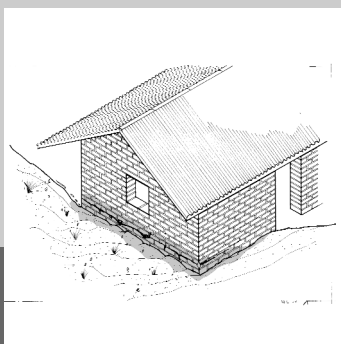
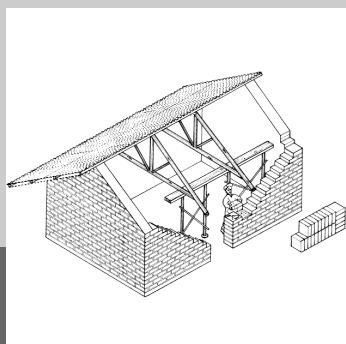
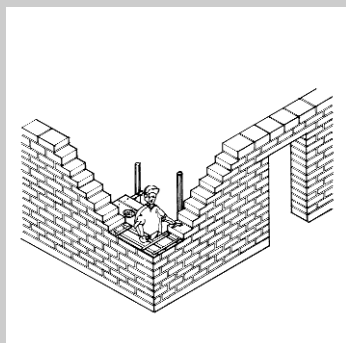
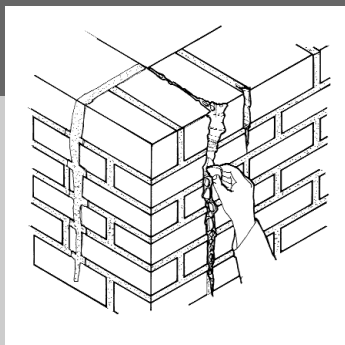

MISEREOR



PRELUDE

Earthquakes have a considerable effect on adobe houses built with a large number of building defects and on unsuitable ground, or simply houses that are too old and have not been regularly maintained by their occupants.

Water is another enemy of adobe buildings. Earthquakes simply reveal the deterioration suffered due to water (rain, humidity, filtration, etc.)

This is why it is important to periodically check and carry out maintenance on houses in order to avoid progressive deterioration and thus protect them from and anticipate earthquakes.

After an earthquake many houses resist well or suffer some damage which can be repaired without needing to demolish the house. The aim of this handbook is to assist engineers and the population at large in repairing houses correctly.

The handbook is divided into three main parts:

- 1- **Earthquakes:** how they occur, how they affect houses and the damage they cause.
- 2- **The method:** the steps to follow to repair a house.
- 3- **Repair:** the most vulnerable parts of a house in the face of an earthquake, with alternative repairs.

"REHABILITATION: ANTI-SEISMIC CONSTRUCTION HANDBOOK"

Authors. Arch. Wilfredo Carazas Aedo - Arch. Alba Rivero Olmos
Scientific coordination: CRATerre-EAG Team.
Document financed by MISEREOR

Editions CRATerre
Maison Levrat, Parc Fallavier, BP 53
F-38092 Villefontaine Cedex, France

THE ORIGIN OF EARTHQUAKES

The earth dates back approximately 4.5 million years. Since this period the internal mass of the earth has been constantly moving, transforming the continents. The globe has a radius of 6,400 km and consists of several successive layers. If we look at a cross-section, we will see: the nucleus, the mantle and the earth's crust.

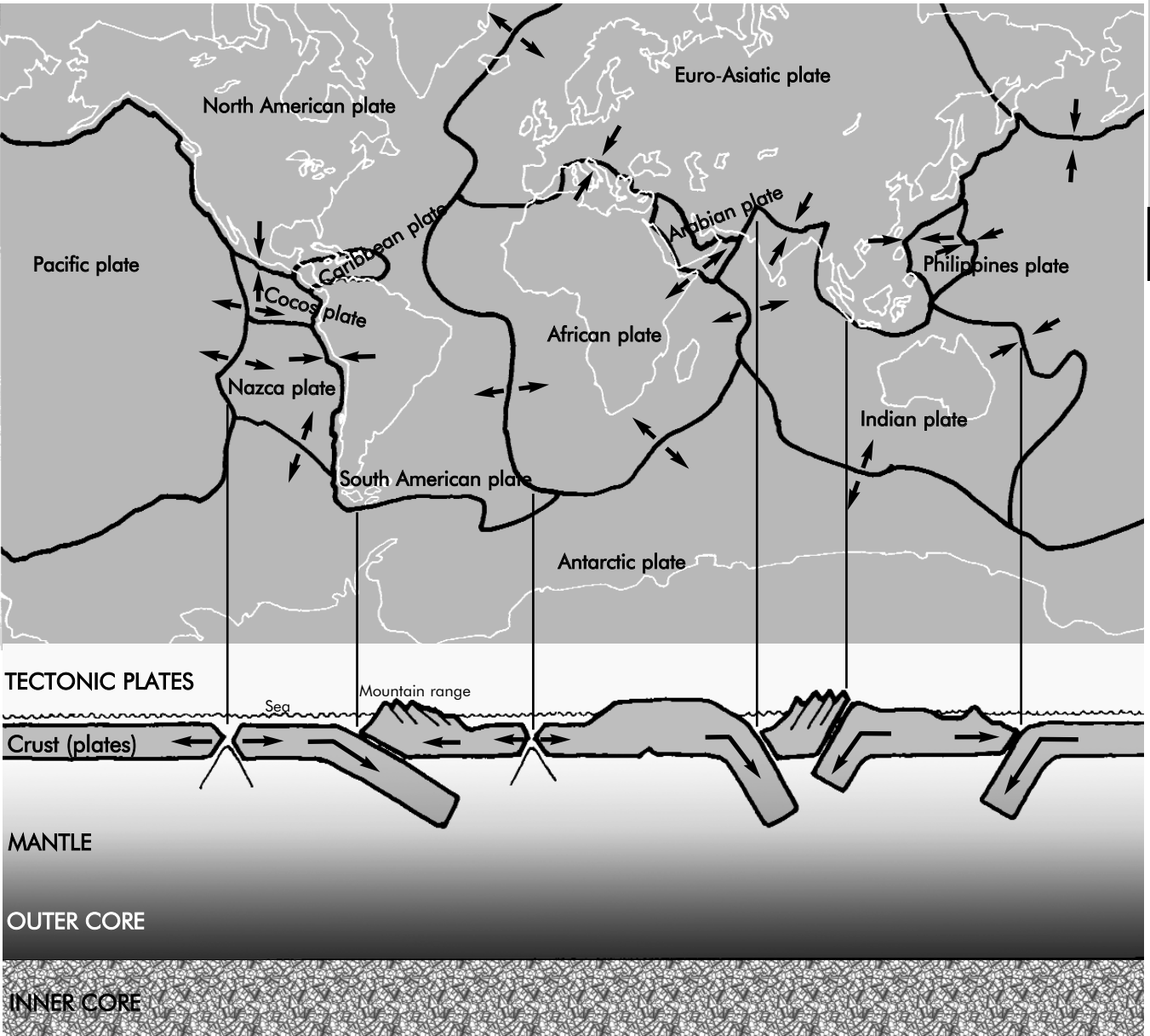

There are several plates on the earth's crust, they differ in the way they behave: some move apart, others collide and others simply move one on top of another. These plates move slowly at an average speed of 1 cm to 15 cm per year. These movements produce deformations which lead to forces which exceed the resistance of materials and free accumulated energy. This is what generates **EARTHQUAKES**.

SEISMIC PRINCIPLES:

Initial position

Seismic action

Return to initial position

Final position

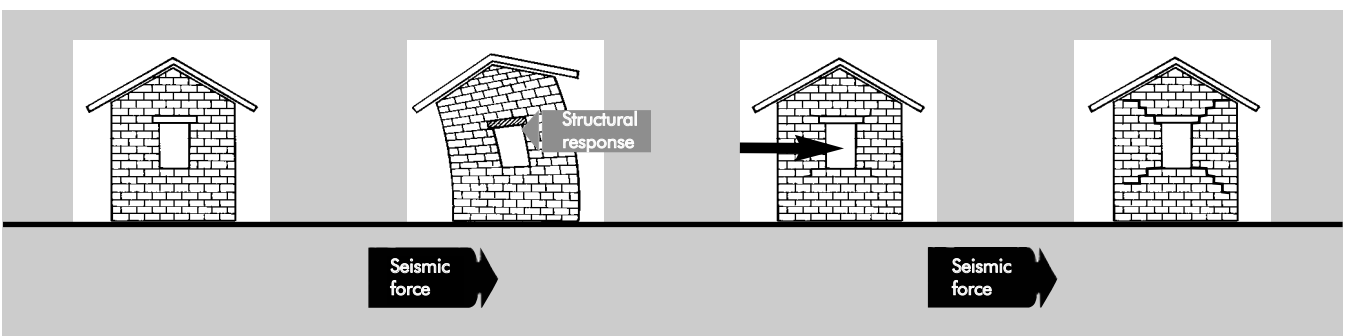

FORCES SISMIQUES

When an earthquake occurs, a house is shaken by vertically oscillating movements, horizontal forces and torsion, all at the same time. The house will respond according to its characteristics: its shape and type of material. To understand this better we shall separate these three movements.

ACTION

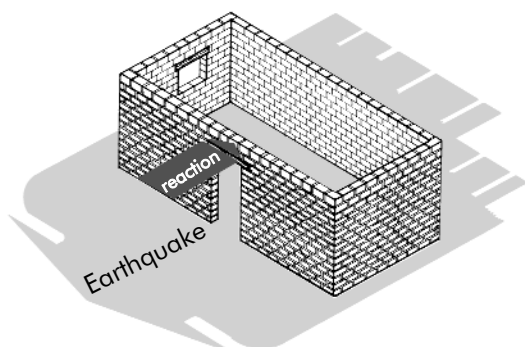

EFFECTS

Horizontal forces

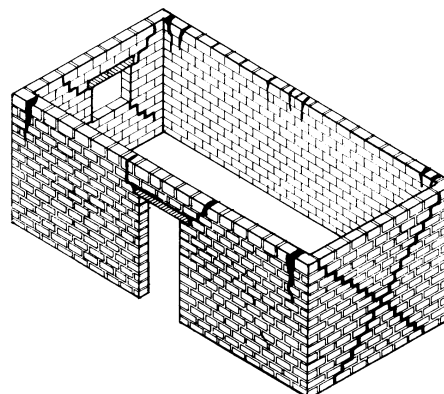

Horizontal forces: Seismic waves make the ground vibrate creating horizontal forces in the construction which is shaken, rocked, deformed and demolished. This bending and tearing of the wall loosen it and make it slide concerning to the foundation.

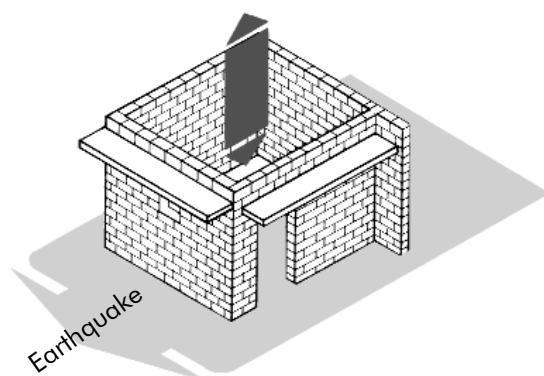

Vertical oscillation

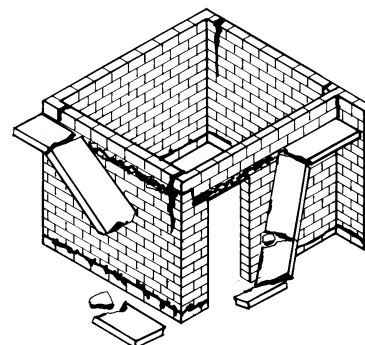

This is another type of oscillation which occurs during an earthquake. Its effects are minimum, only heavy parts are affected, such as arches, columns, roof structures, and also projecting parts like balconies and eaves, etc.

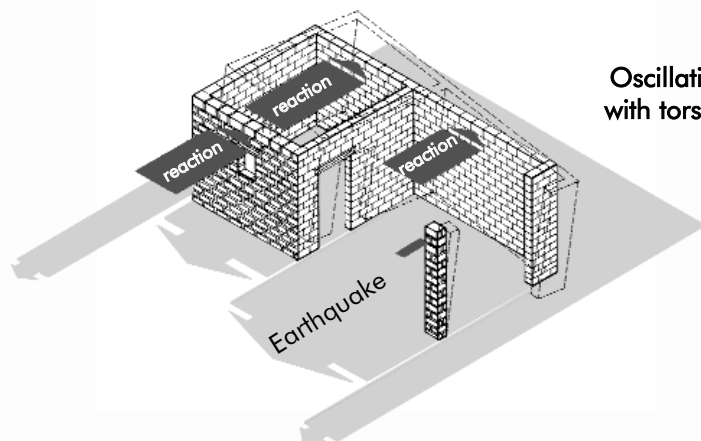

Oscillation with torsion

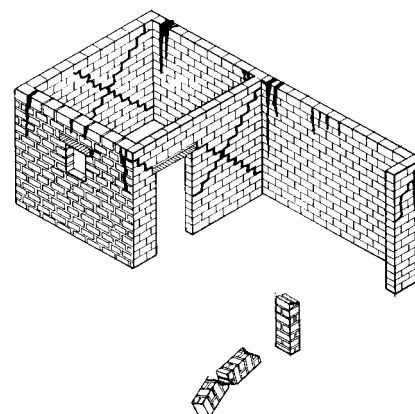

Finally, oscillation with torsion is the result of horizontal movements of the ground together with lateral forces. The effects of torsion are more or less important depending on the shape of the construction, for example irregular shaped houses where the centre of gravity does not coincide with the centre of rigidity will be more exposed to damage.

THE EFFECTS OF AN EARTHQUAKE ON A HOUSE

To face an earthquake, a house must satisfy minimum technical requirements, correctly using materials and optimizing the design. For example, some features should be avoided, such as: irregular shaped houses in terms of size and height.

Type of wall

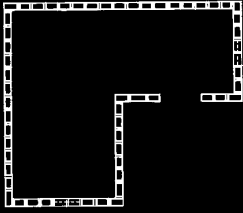

L-shaped construction

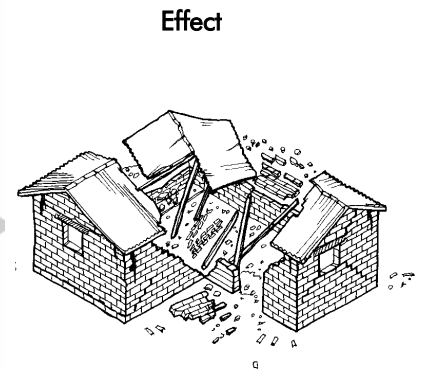
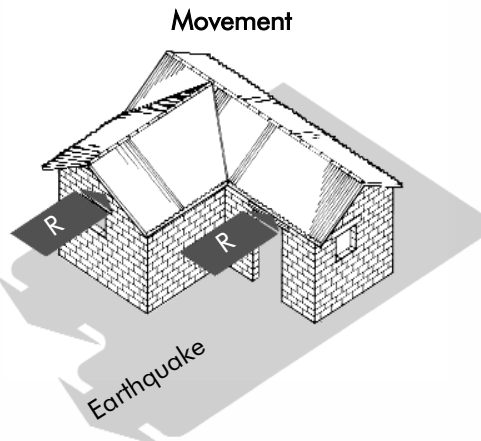

This house has walls with different dimensions which in an earthquake will behave deficiently making the house collapse more quickly.

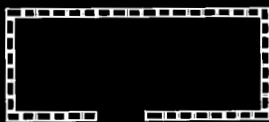

Rectangular construction

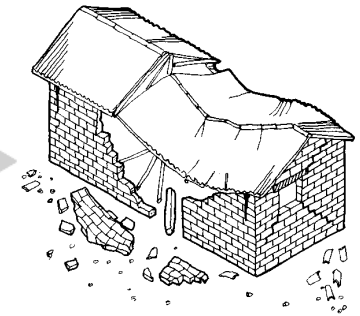
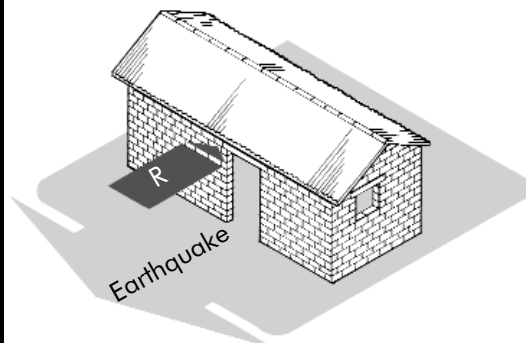

Its wide walls without intermediate supporting walls and with weak corners are less resistant in an earthquake making it collapse.

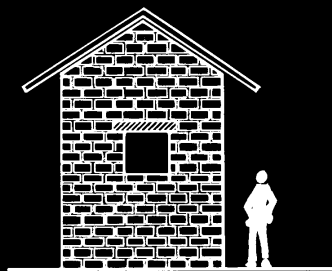

High construction

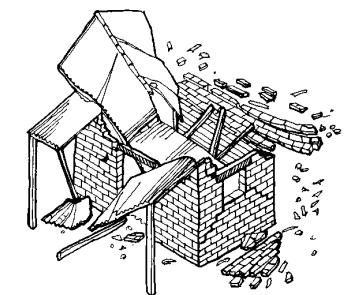
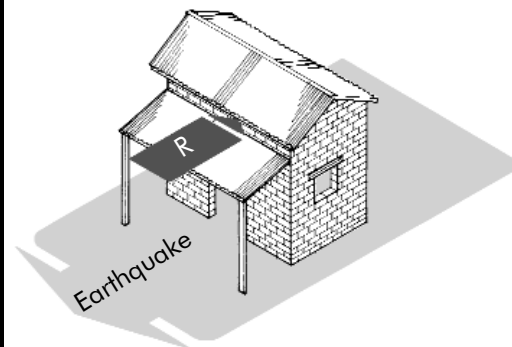

Due to its high thin walls it is more flexible and less resistant to earthquakes.

Other examples of features to be avoided include:

- "T" and "C" shaped buildings,
- Storey buildings.
- Ceiling panel beams located directly above the wall.
- The use of inside walls as support for the roof.
- Constructions built on slopes,
- Wide spaces between the walls.
- Columns, arches, domes and vaults.

METHOD

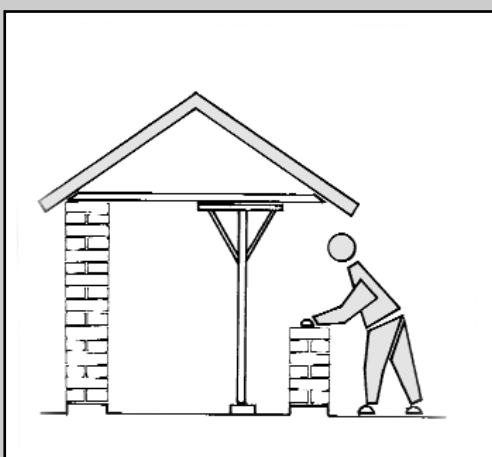
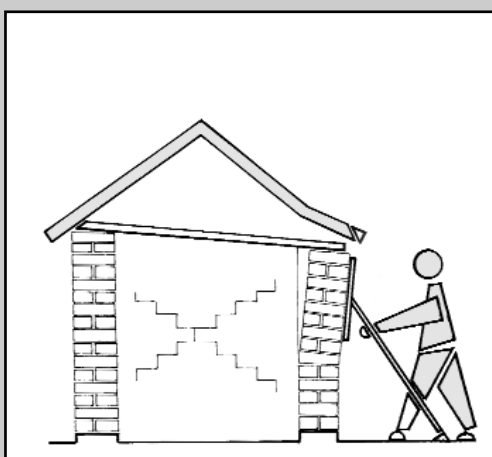
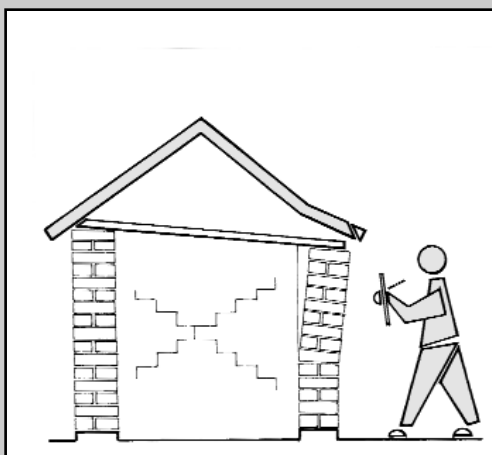

OBSERVE

After an earthquake, if the house is still standing, the first thing to do is to carry out a detailed assessment of its physical condition:

- check damage and analyse causes (construction errors, location).
- decide whether the house can be repaired or needs to be demolished.
- if you decide to demolish the house, this should be done immediately.
- if you decide to repair it, the house should be fully assessed including the type of damage, priorities and steps

SUPPORT

Once the assessment has been carried out, stabilise the damaged parts of the house supporting them appropriately until they are repaired.

- if necessary, delimit access to the house during this period so as to avoid accidents.

REPAIR

Based on the assessment, draw up a list of priorities for the restoration phase, beginning with the areas with greatest damage.

- dismantle and reconstruct the damaged parts.

ROOFING

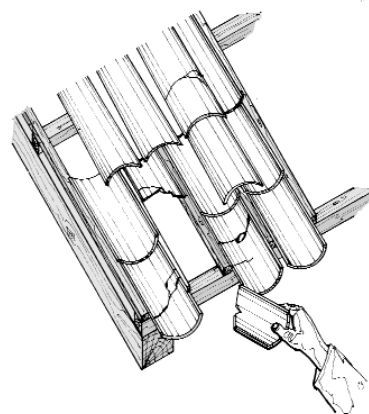
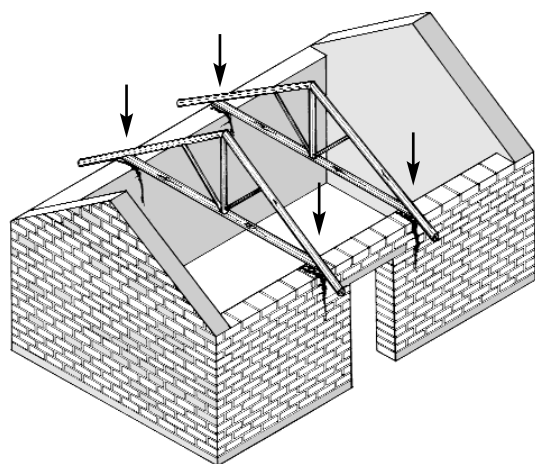

After an earthquake, there will be cracks in the part which supports the load of the roof, mainly when the ring beam which distributes the load horizontally is missing.

The first thing to do is to remove the roof tiles so as to avoid them continuing to fall and to free the structure to fit the support more easily. This is especially true for colonial style tiles which have a considerable weight and which can cause accidents when they fall.

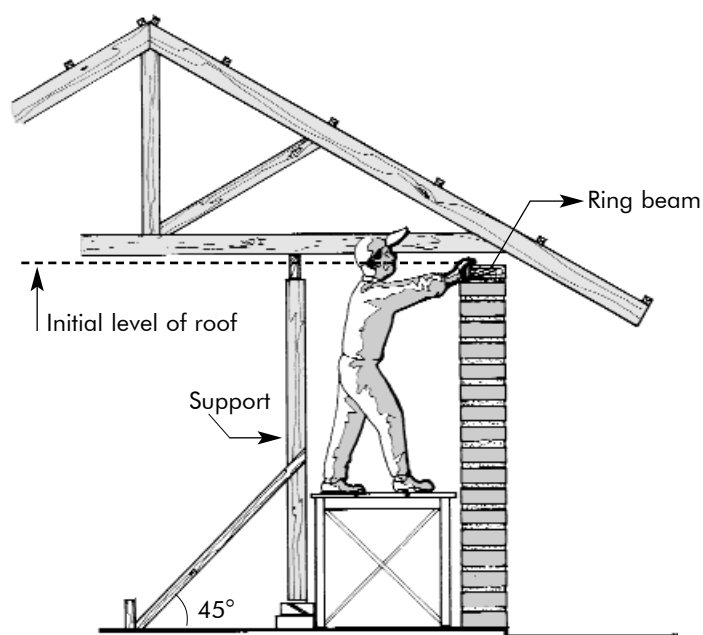

Once the roof has been supported, the damaged adobes are eliminated and replaced. The final layer of adobe is removed and replaced with a ring beam or a wall plate (made from wood, cement, bamboo or a similar material). Afterwards the roof structure will return to its initial position.

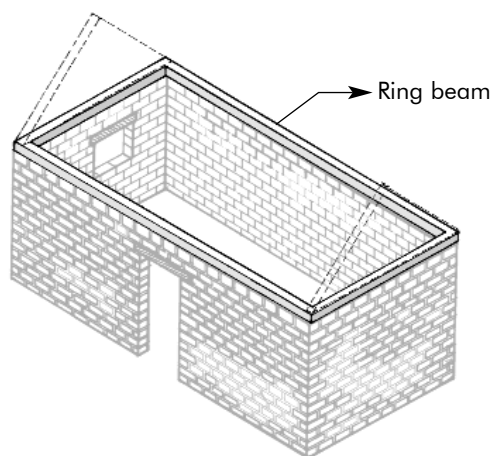

There are two ways of fitting a ring beam:

- 1- Build a ring beam around the wall's entire perimeter if the wall is not gabled.
- 2- Or only on the parts which receive the roof, finishing at the ends with a key embedded in the gabled wall.

GABLED WALL

Alternative 1. Repair the Gable

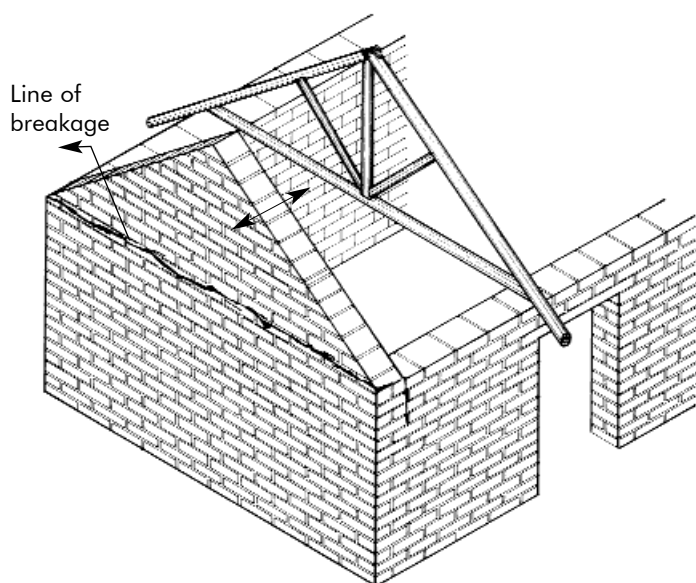

Cracks in gabled walls are frequent after earthquakes because generally they are free-standing without braces.

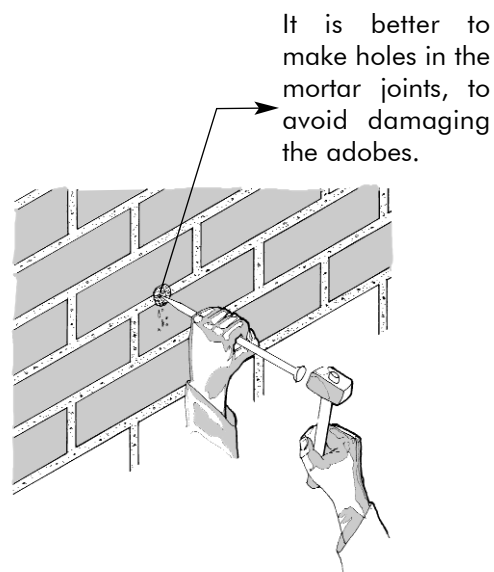

To fit the keys it is advisable to drill the wall to make 5 cm diameter holes to fit the construction irons embedded in the cement mortar.

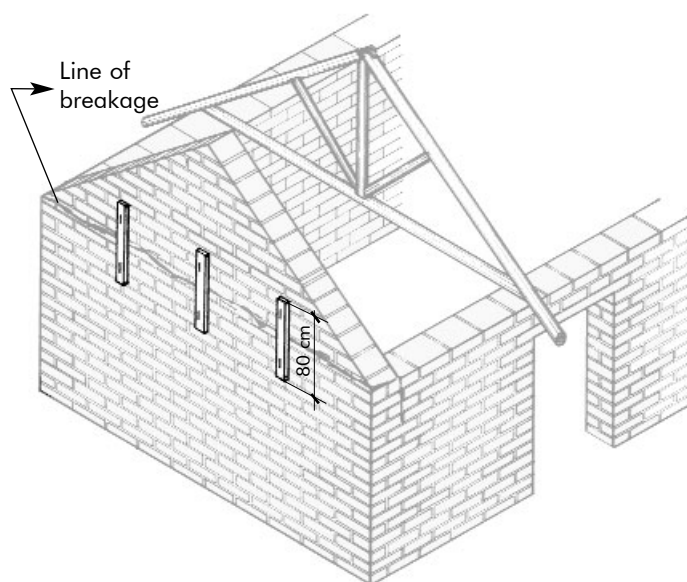

If during the assessment we observe that the gable is broken but stable and vertical, then we can repair and reinforce it with keys placed at a right angle to the line of breakage.

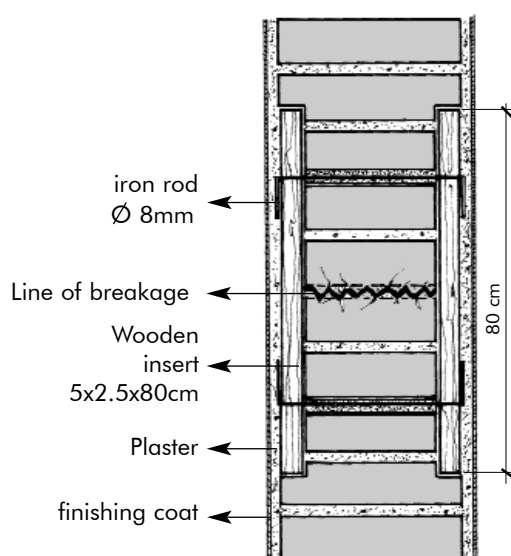

Detail of the fitting of the key at a right angle to the line of breakage.

GABLED WALL Alternative 2. Lightened Gable

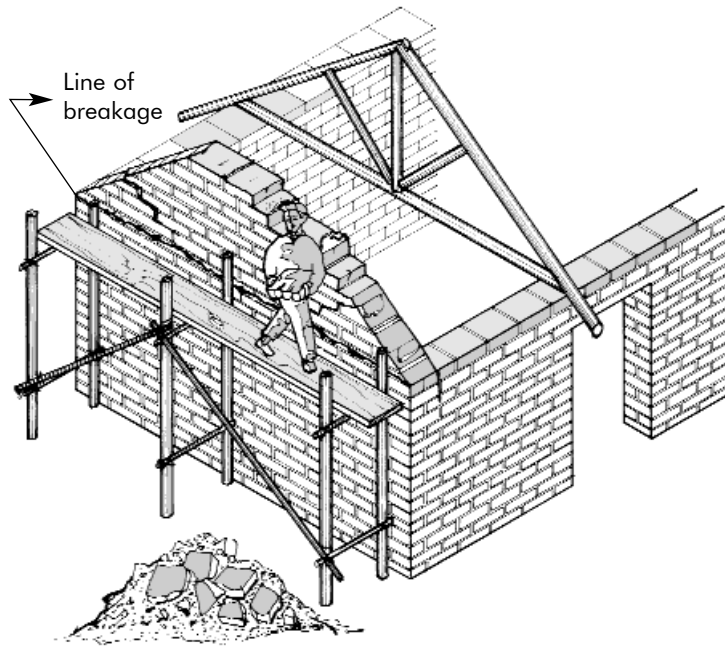

If the earthquake has caused serious damage in the gabled wall and part of it has collapsed, then it is advisable to dismantle it and change it for a frame or a weatherboard which will be much lighter and more resistant in the event of an earthquake.

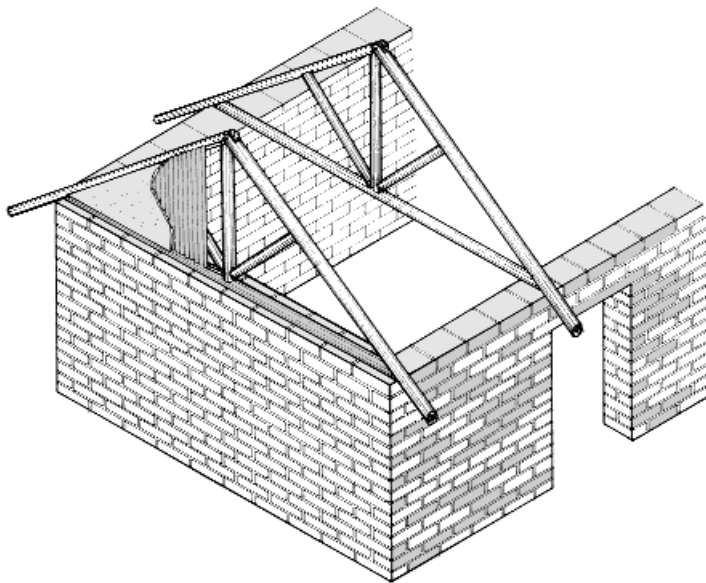

Using the "wattle and daub" technique, consists of making a frame with cane , poles or made from a similar material, covered with clay mortar.

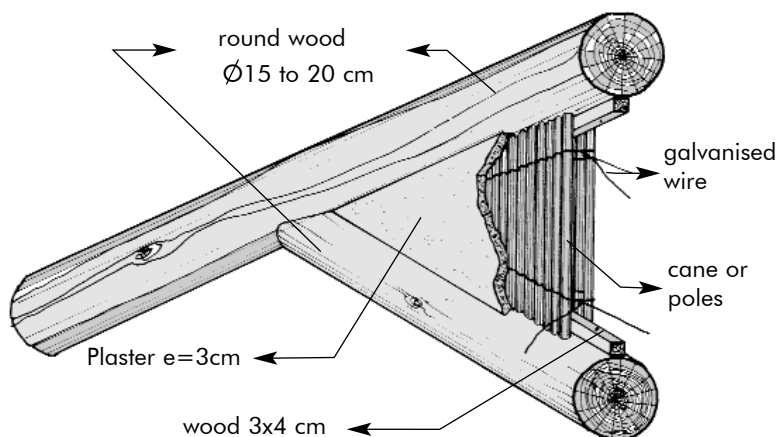

This drawing of the gable structure shows in detail the solution with cane or poles tied with galvanised wire and covered with earth mortar.

WALL CORNERS

Alternative 1. Reinforcement with Keys

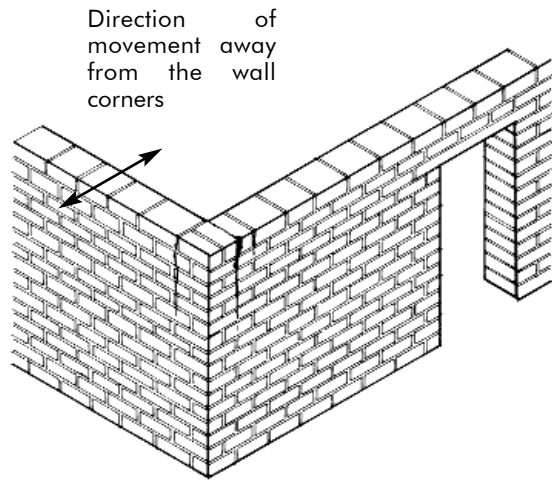

Corner joints tend to be weak areas in the event of an earthquake, especially when they do not have correct bonding.

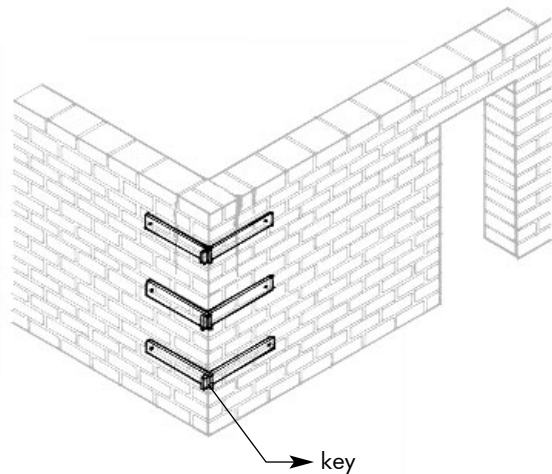

If the cracks are not serious and there is no loosening, then they can be repaired by fitting keys. It is advisable to fit them at 5 row intervals taking advantage of the mortar joints. Take great care when cutting the wall to fit the wooden parts which make up the key so as to cause as little damage as possible to the adobe. Afterwards cover any remaining spaces between the key and the wall with clay and straw mortar.

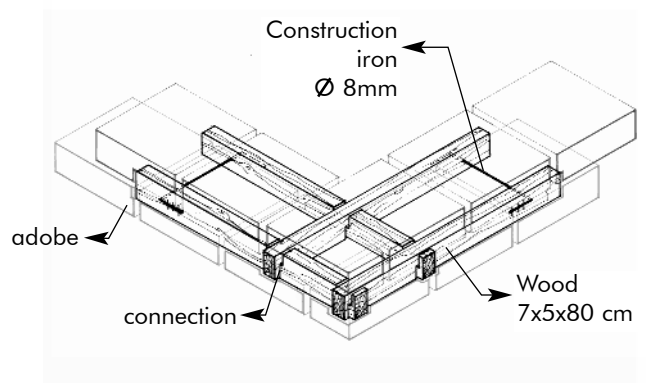
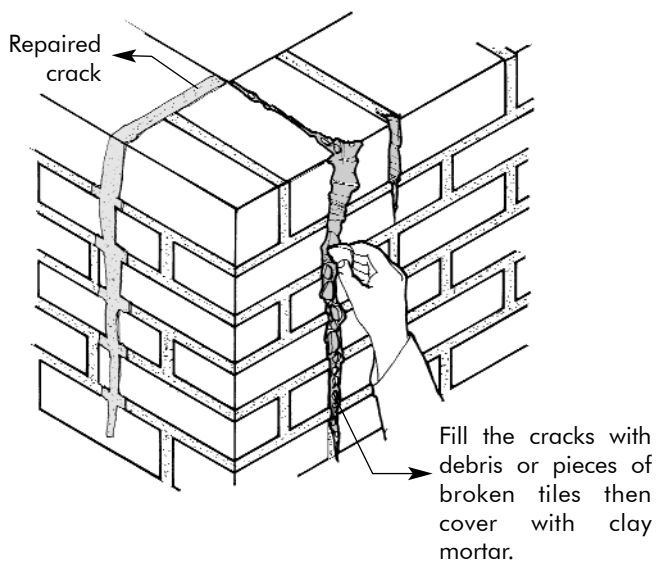

Detail of the key

The wood must be joined together with "male-female" type joins.

WALL CORNERS

Alternative 2: Dismantling and Reconstruction

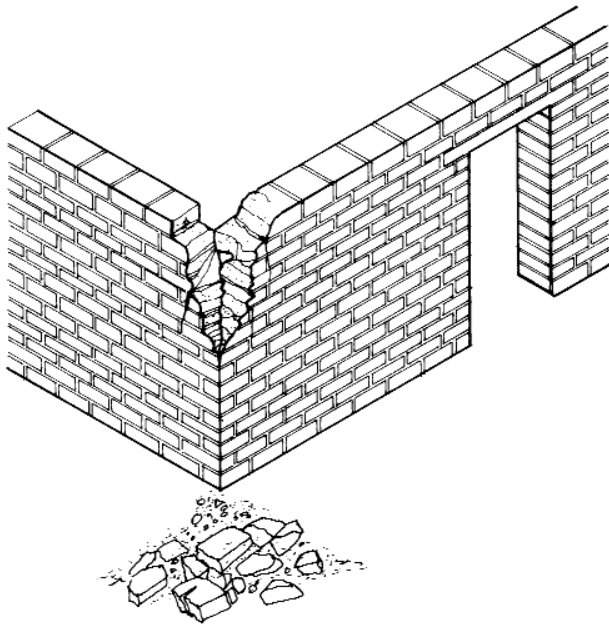

When the walls have suffered greater damage, like collapsed sections, a more delicate operation is needed.

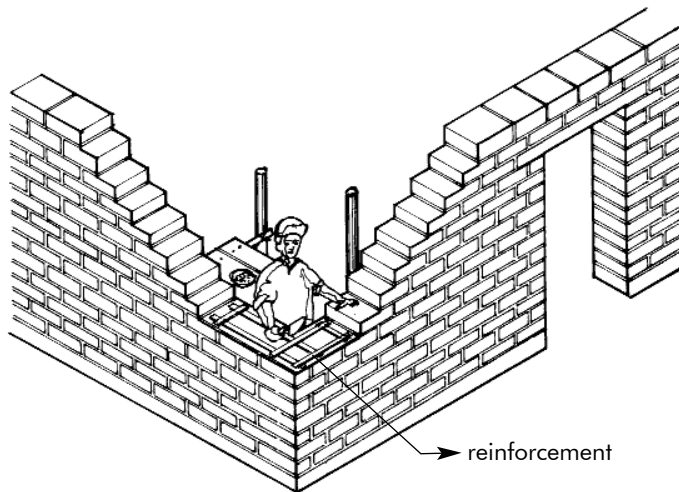

First dismantle the wall in the form of a "staircase" on both sides, then rebuild the wall with new adobe bricks. In order to avoid this happening again, fit supports at 4 row intervals (keys), these will be embedded in the wall. Another possibility is to rebuild with buttresses, in which case you will need to start from the foundations.

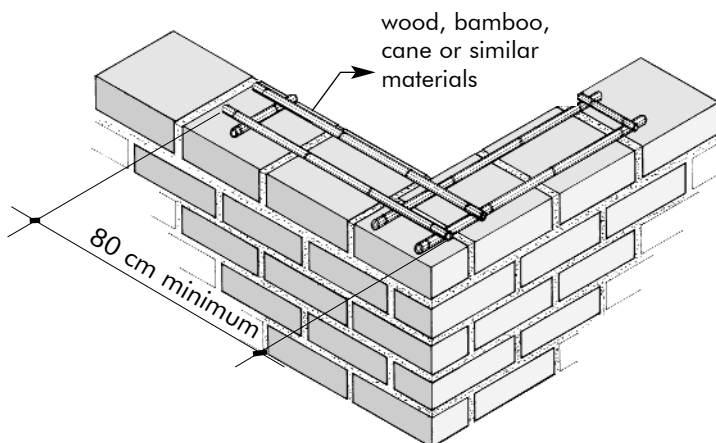

This drawing shows an alternative option to insert "keys". This solution uses wooden sticks or canes, and is equally efficient, in the event of an earthquake. Other materials and techniques can also be used: wood, bamboo or wire mesh with concrete.

WALLS

After an earthquake, if a wall has become out of plumb by more than 2% per metre, then it will need to be dismantled or completely demolished since this deformation makes the wall lose its carrying capacity. To do this you will need to dismantle the wall after having checked the stability of the roof as described above.

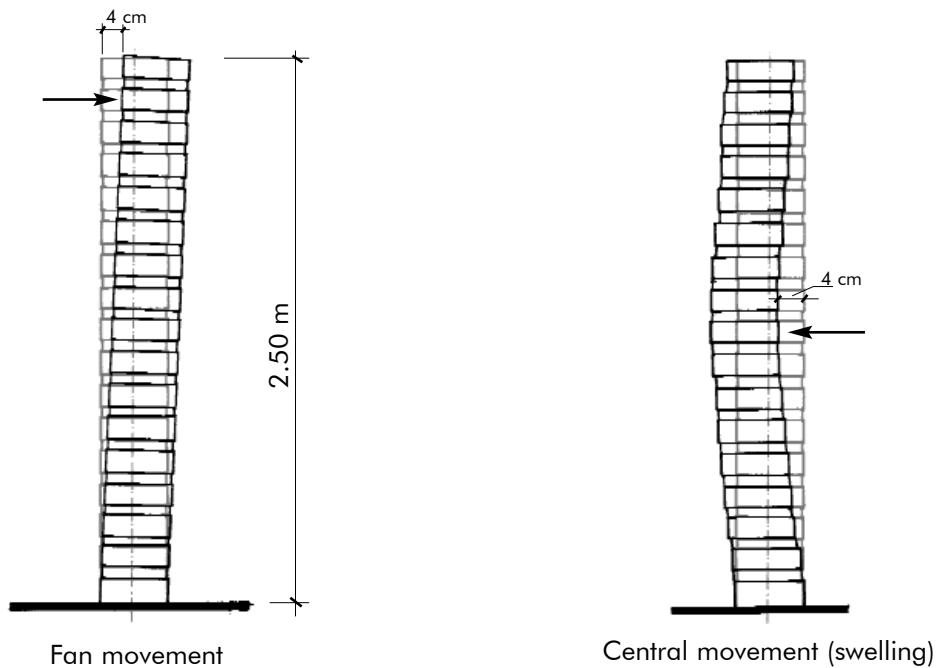

If the out of plumb is less than 1% and the walls do not show any signs of damage or diagonal cracks which cross it completely, the affected parts can be repaired.

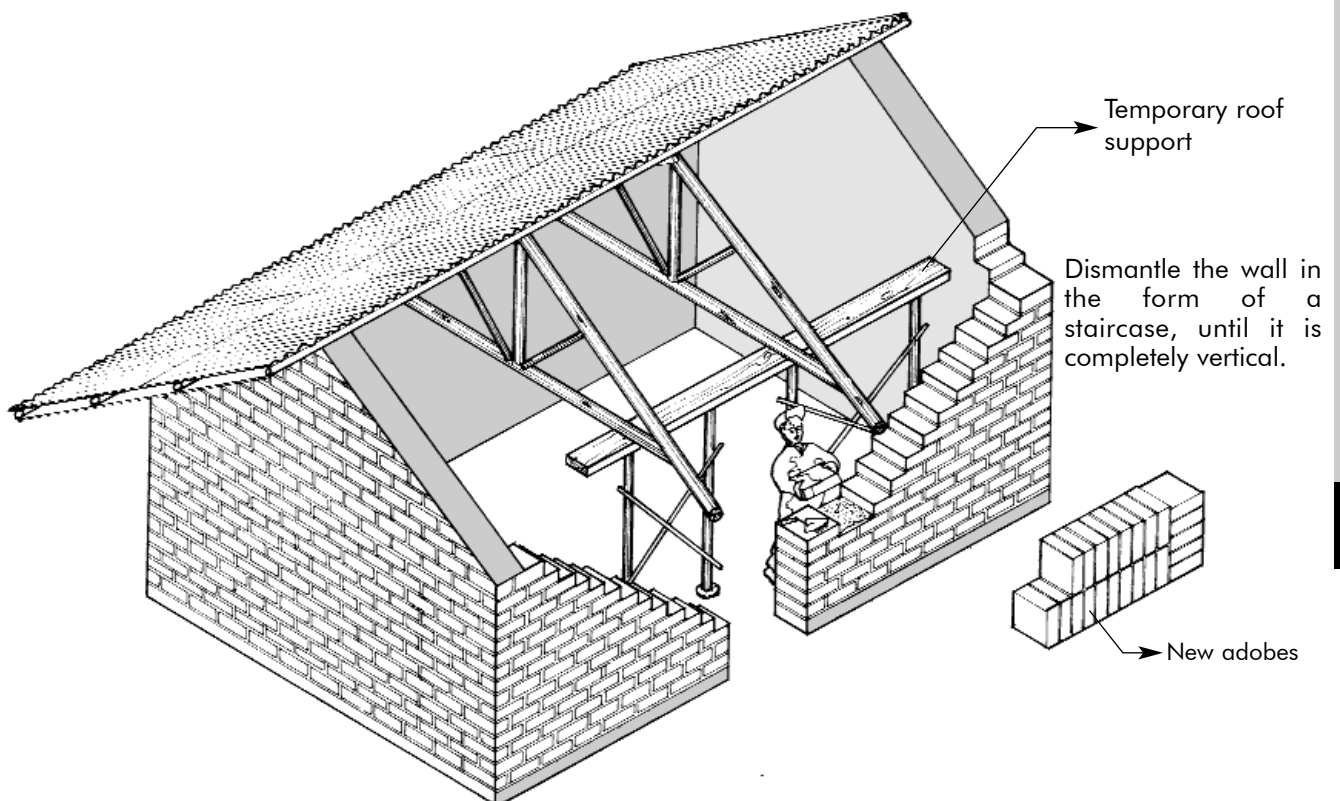

FOUNDATIONS & WALL BASE

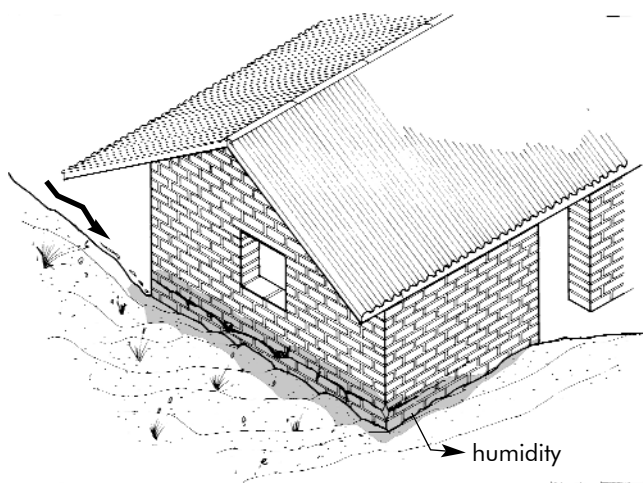

One of the most frequent causes of deterioration of the walls of a house is their direct contact with the ground humid thus making them vulnerable in the event of an earthquake.

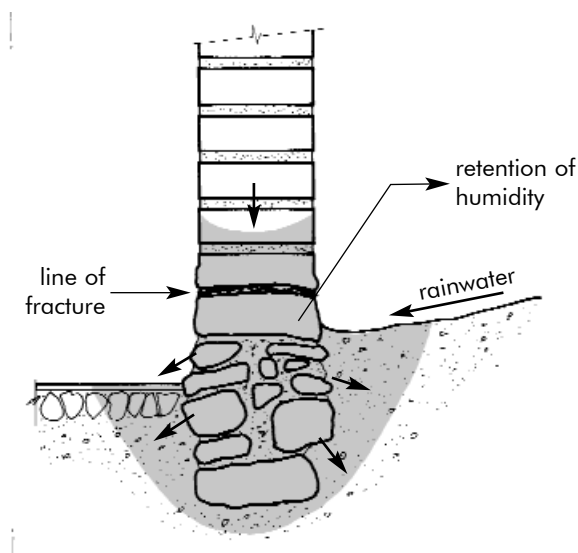

Example: ground sloping towards the wall, unstable and poor quality foundations and wall bases, prone to settling due to the effect of humidity and the inferior quality of the ground.

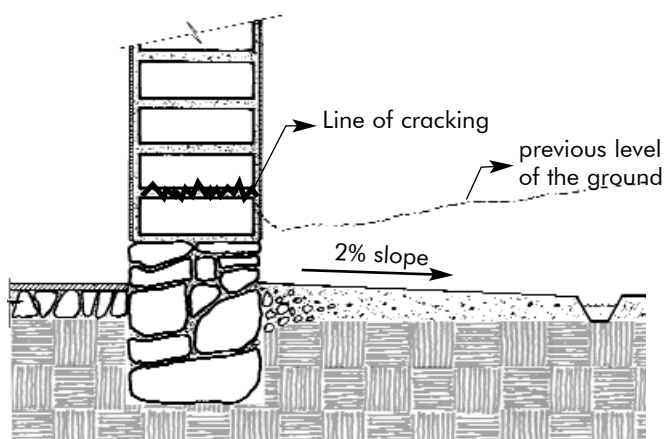

Alternative 1: Cleaning & Drainage

If after an earthquake the wall has cracks in certain sections and the adobe bricks are in a satisfactory state we must eliminate the earth which covers the wall base, and level out the ground a minimum of 10cm below the wall base.

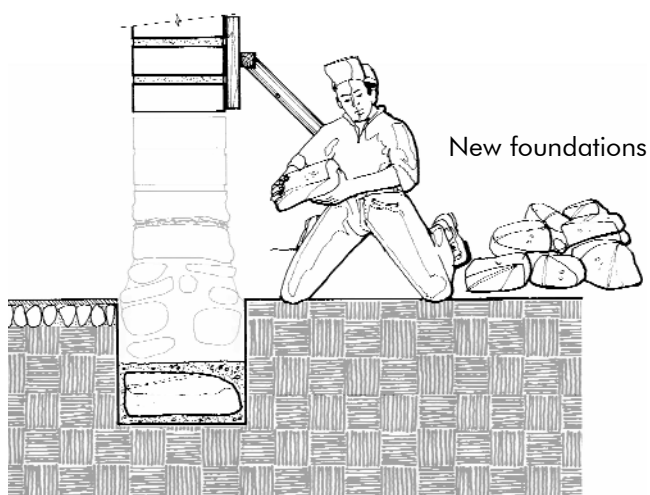

Alternative 2: Demolition & Reconstruction

If after an earthquake the base of the wall has become loose, if there are cracks in the entire wall and sinking which make the wall unstable and dangerous we must then:

Dismantle it after propping it up and build a new wall from the foundations.

STEPS FOR REPAIRING WALLS

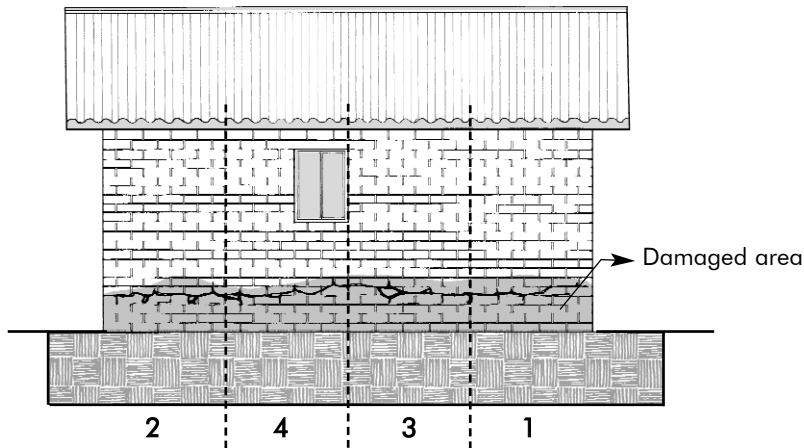

To correctly repair the length of a wall proceed as follows:

First: divide the length of the damaged area into distances of 1.20m - 1.50 m, beginning at the ends.

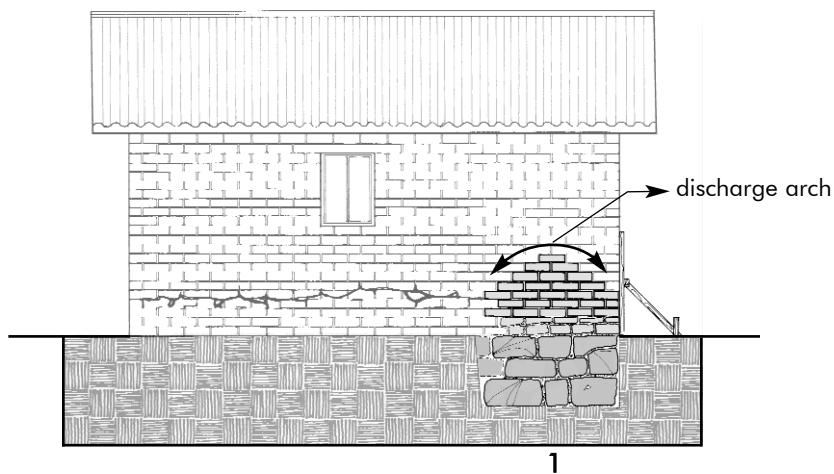

Second: once you have divided the wall, support the sides only, then dismantle the first part selected forming the so-called **discharge arc**. After start to rebuild the foundations and wall base (if these have been affected or are inexistent), and finally the wall.

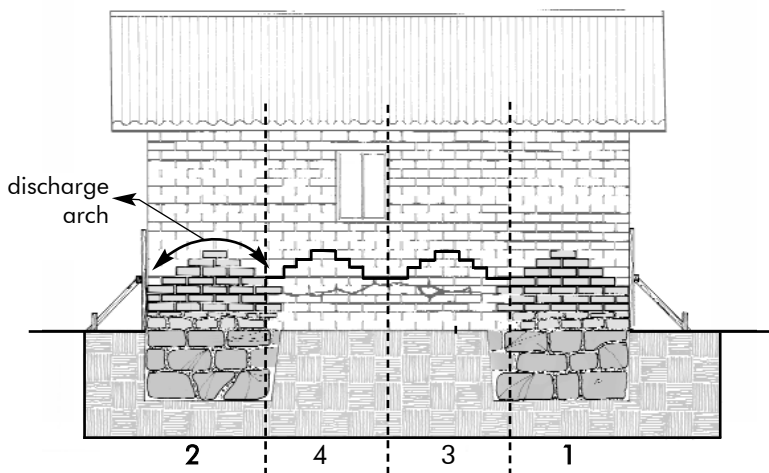

Third alternate between the different ends so as to stabilise the house and successively finish the selected parts, position 3 and position 4.

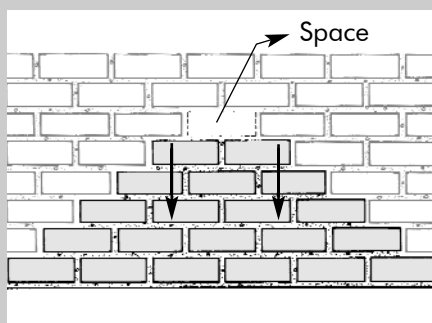

-before fitting the final row of adobe bricks allow the wall to dry and settle in its final position (shrinkage and own weight)
-once the final adobe brick has been fitted, it is important to fit some flat pebbles in the upper joint so as to stabilise the entire wall.

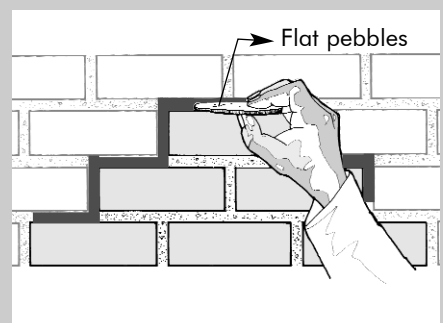

REPAIRING THE PLASTER

After an earthquake, typical cracks can be noticed in the wall. Earthquakes also affect the plaster, which suffers from cracking and loosening.

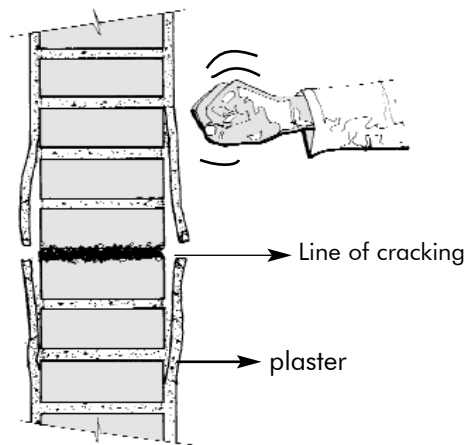

Checking Damage

Check the parts of the plaster which have become loose by hitting. If they sound hollow this means they are disconnected from the wall. In this case, remove the damaged plaster.

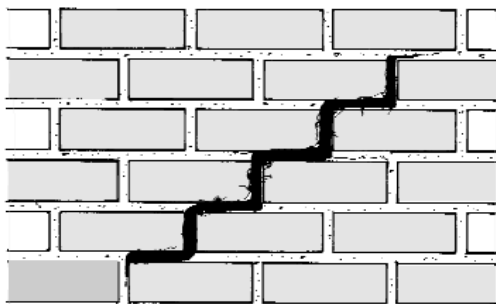

Eliminate any loose plaster

By eliminating damaged parts of the plaster, we can easily check the extent of cracking in the wall and therefore assess repair work needed.

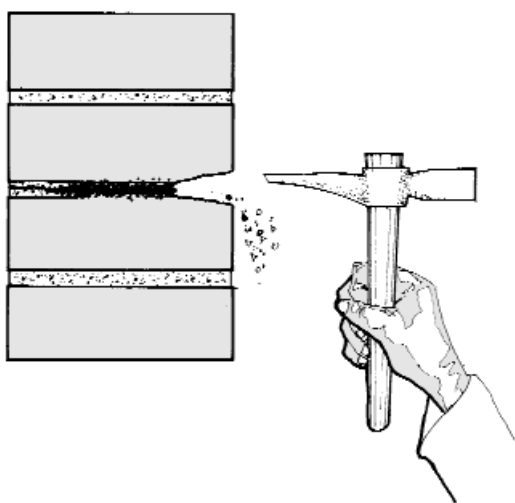

Cleaning

Before repairing the plaster, first repair the cracked wall, cleaning out the line of cracking.

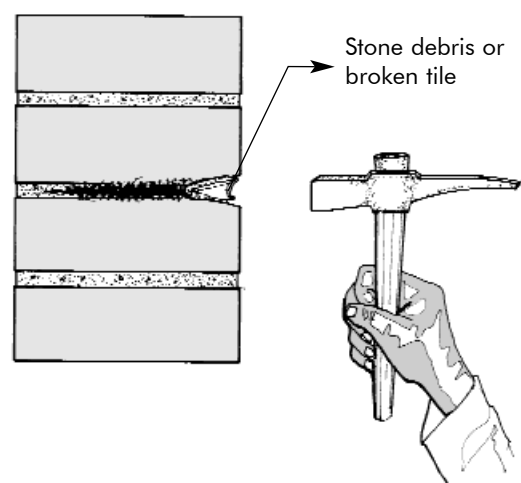

Filling

Place several pieces of stone or broken tiles, pressing them in, then cover with clay mortar. After drying make the new plaster match the existing plaster