

WATTLE & DAUB

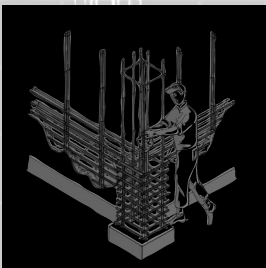

Anti-seismic construction handbook

Wilfredo Carazas Aedo
Alba Rivero Olmos

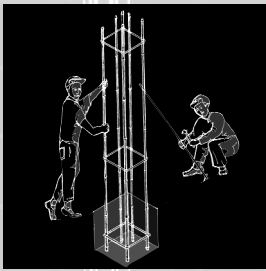

PRELUDE

Historic records show us that mixed construction systems were developed in the early ages of civilizations and that man learnt to build his home using earth and vegetal structure, thus giving rise to interesting forms of dwellings, showing intelligent building cultures.

Today in different parts of the world we can appreciate this building heritage and we can also examine its continuity, despite the attacks of nature, especially earthquakes.

This alternative form of building (structure and filling) is known under different names according to different regions: in Peru "Quincha", in Cuba "Cuje", in El Salvador "bahajareque", "pao pique" in Brazil and "tabiquería" in other countries. There is thus a wide variety of types or forms of building across the world but which all share the same characteristic.

It is proven that wattle and daub and similar construction materials resist earthquakes satisfactorily and that its physical and mechanical properties are suitable. Recent earthquakes (for example in Central America) are witness to this and scientific studies carried out confirm the efficiency of this building system.

The aim of this construction handbook is to provide theoretical and technical support for use by building engineers, construction workers and all those who decide to build their own house.

The handbook is divided into three main parts:

- 1 - **Earthquakes**: how they origin, how they affect houses and a definition of anti-seismic houses.
- 2 - **Raw materials**: all the main raw materials used to build wattle and daub constructions (wood, bamboo or similar materials and earth).
- 3 - **Anti-seismic construction**: the design, implementation and different stages of construction.

Furthermore, an appendix is included with details of the "La Semilla: Wattle & Daub - Ceren" project and its development.

We have structured the handbook in this way so as to give the builder or dweller a clearer idea of the reasons for the dimensions, form and building technique, which although initially may have certain limits, also provide a more earthquake resistant house.

A house is only considered anti-seismic once it has satisfied all the required parameters: **correct design, quality of the ground, quality of construction and building materials.**

"WATTLE & DAUB : PARASEISMIC CONSTRUCTION HANDBOOK"

Authors. Arch. Wilfredo Carazas Aedo, Arch. Alba Rivero Olmos
Scientific coordination: CRATerre-EAG Team.
Diagrams: Arch. Alba Rivero Olmos
Drawings. Arch. Wilfredo Carazas Aedo

Document financed by **MISEREOR**
Editions CRATerre
Maison Levrat, Parc Fallavier, BP 53
F-38092 Villefontaine Cedex, France

THE ORIGIN OF EARTHQUAKES

The earth dates back approximately 4.5 million years. Since this period the internal mass of the earth has been constantly moving, transforming the continents. The globe has a radius of 6,400 km and consists of several successive layers. If we look at a cross-section, we will see: the nucleus, the mantle and the earth's crust.

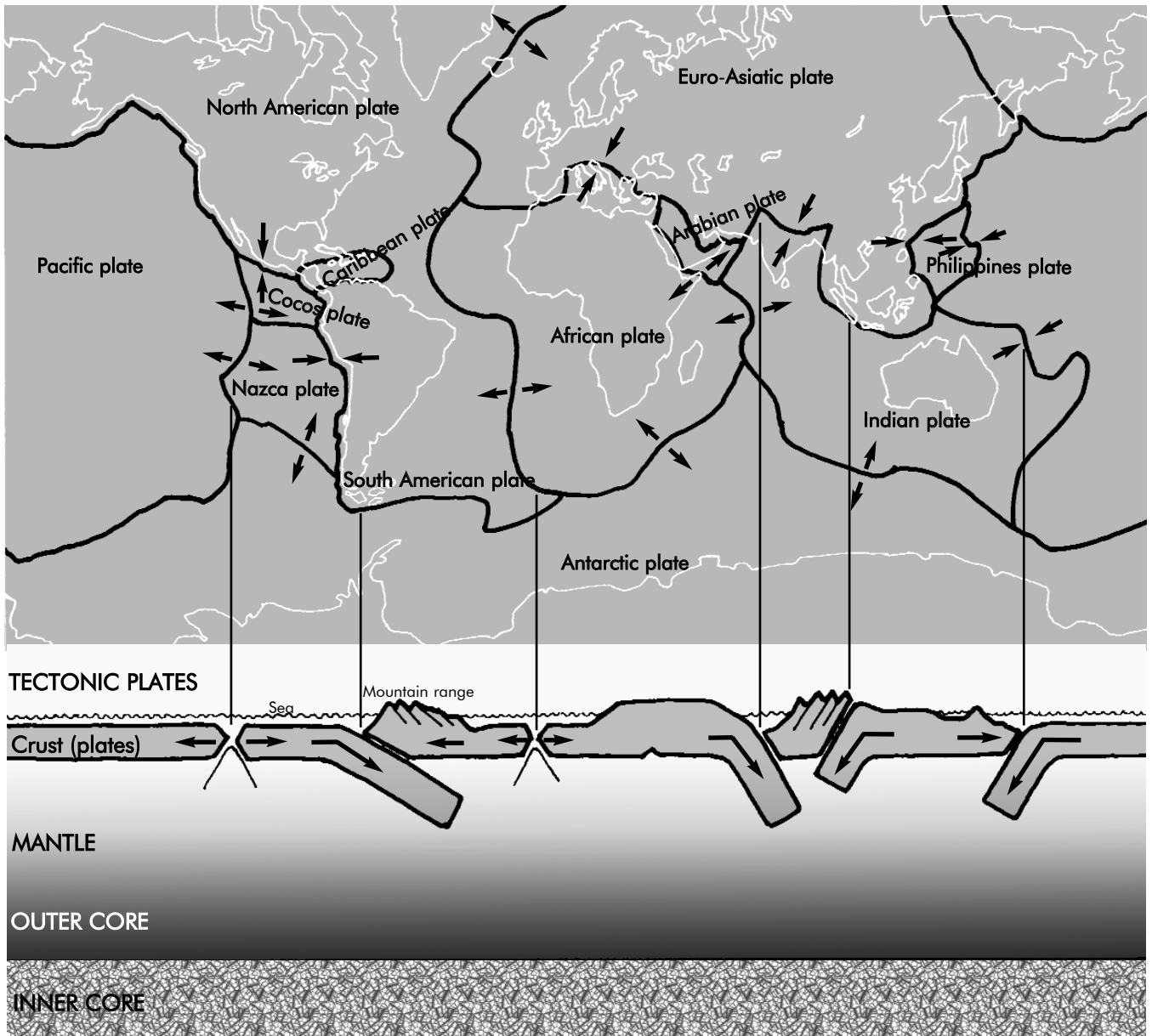

There are several plates on the earth's crust, they differ in the way they behave: some move apart, others collide and others simply move one on top of another. These plates move slowly at an average speed of 1 cm to 15 cm per year. These movements produce deformations which lead to forces which exceed the resistance of materials and free accumulated energy. This is what generates **EARTHQUAKES**.

SEISMIC PRINCIPLES:

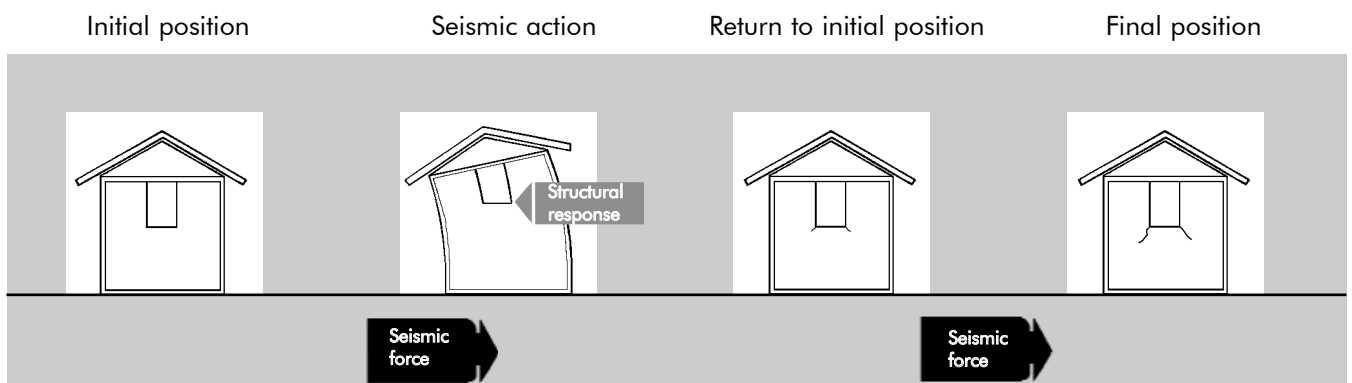

FORCES SISMIQUES

When an earthquake occurs, a house is shaken by vertically oscillating movements, horizontal forces and torsion, all at the same time. The house will respond according to its characteristics: its shape and type of material. To understand this better we shall separate these three movements.

ACTION

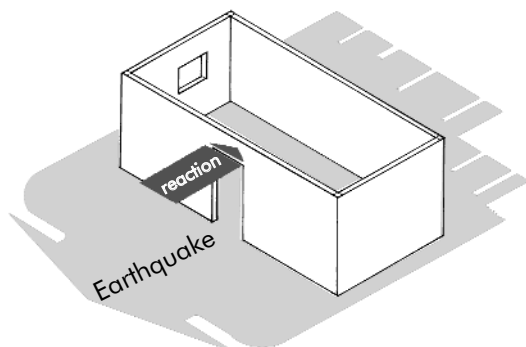

Horizontal forces

EFFECTS

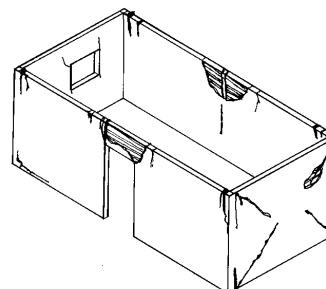

Horizontal forces: Seismic waves make the ground vibrate creating horizontal forces in the construction which is shaken, rocked, deformed and demolished. This bending and tearing of the wall loosen it and make it slide with regard to the foundation.

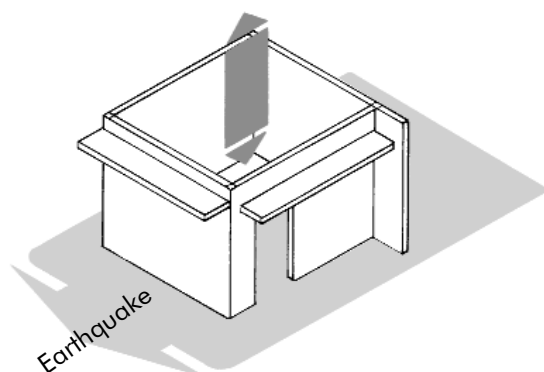

Vertical oscillation

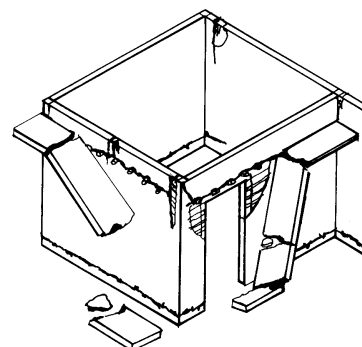

This is another type of oscillation which occurs during an earthquake. Its effects are minimum, only heavy parts are affected, such as arches, columns, roof structures, and also projecting parts like balconies and eaves, etc.

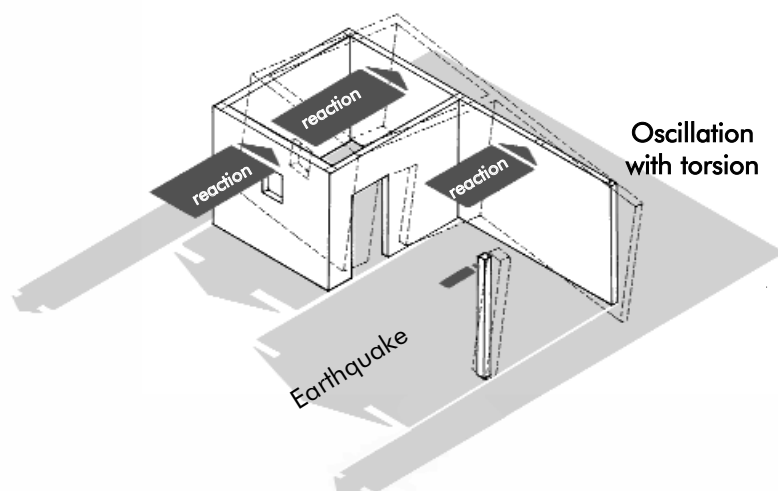

Oscillation with torsion

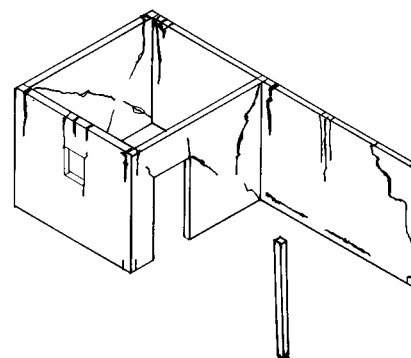

Finally, oscillation with torsion is the result of horizontal movements of the ground together with lateral forces. The effects of torsion are more or less important depending on the shape of the construction, for example irregular shaped houses where the centre of gravity does not coincide with the centre of rigidity will be more exposed to damage.

THE EFFECTS OF AN EARTHQUAKE ON A HOUSE

To face an earthquake, a house must satisfy minimum technical requirements, correctly using materials and optimizing the design. For example, some features should be avoided, such as: irregular shaped houses in terms of size and height.

Type of wall

Movement

Effect

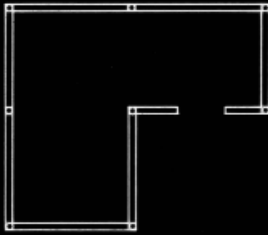

L-shaped construction

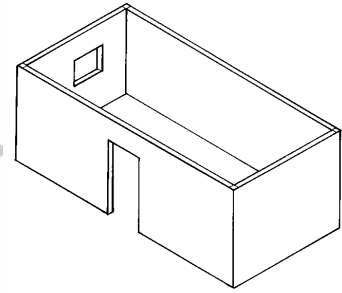
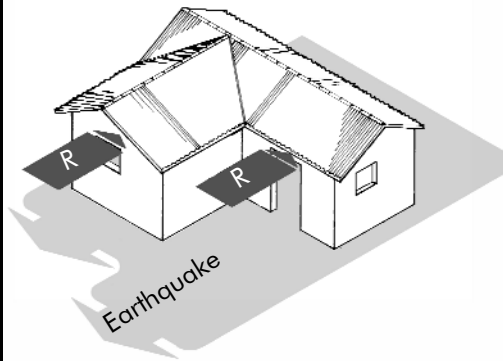

This house has walls with different dimensions which in an earthquake will behave deficiently making the house collapse more quickly.



Rectangular construction

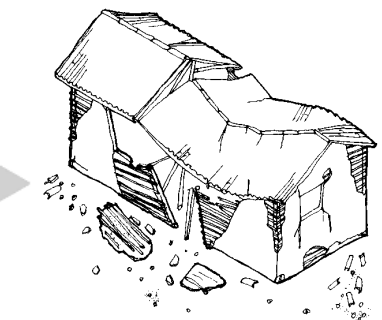
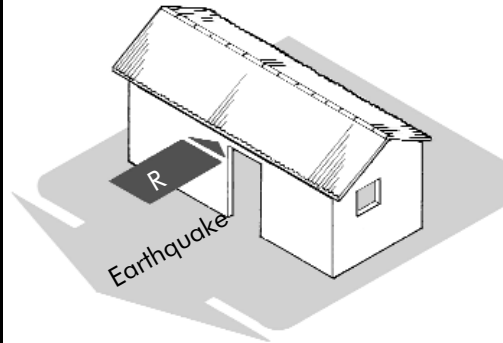

Its wide walls without intermediate supporting walls and with weak corners are less resistant in an earthquake making it collapse.



High construction

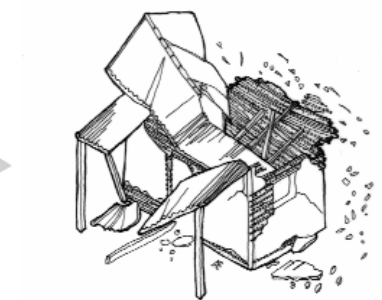
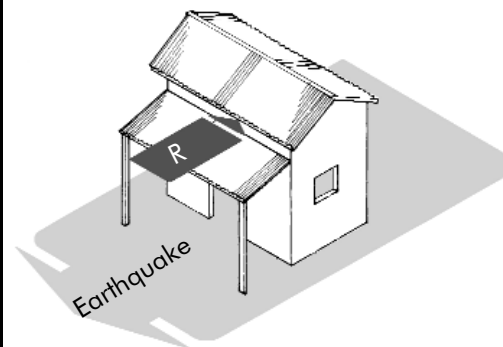

Due to its high thin walls it is more flexible and less resistant to earthquakes.

Other examples of features to be avoided include:

- "T" and "C" shaped buildings,
- Loose roof beams,
- Houses without wall bases,
- Structures with heavy roofs,
- Constructions built on slopes,
- Wide spaces between the walls.

THE ANTI-SEISMIC HOUSE

An anti-seismic house is a house built using a series of appropriate building and design techniques so as to resist an earthquake. The cube shaped house is the basic principle which guarantees anti-seismic resistance, from which we shall develop the necessary technical structural steps.

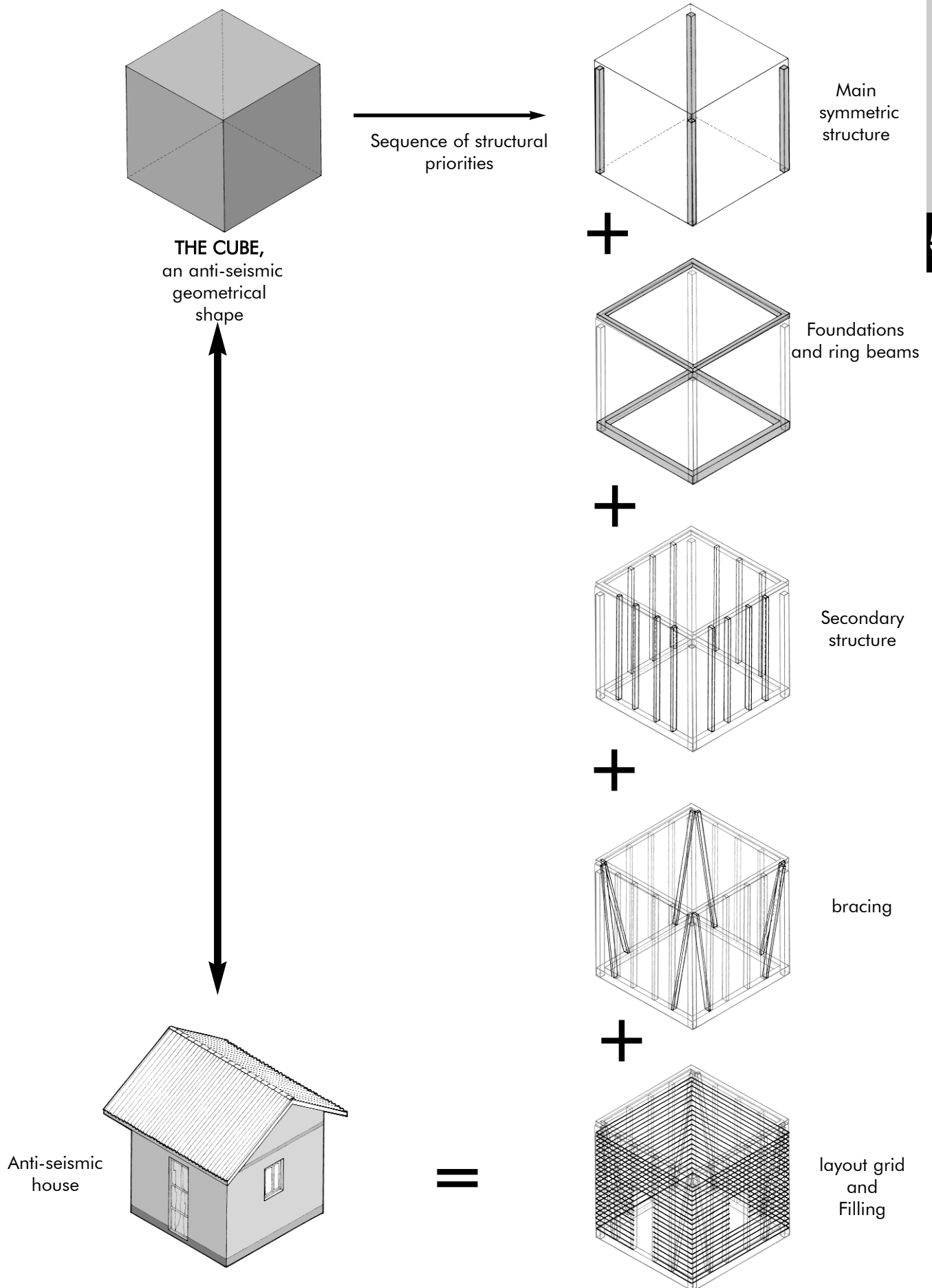

SELECTING LAND FOR BUILDING

Building a house requires a suitable decision with regard to choosing the land. Several basic criteria for recognition are needed: flat and dry land with a hard surface is appropriate. It is better to avoid unsuitable areas for building: reservoirs, cliffs, areas close to rivers, on former mines, on landfill sites, etc. If a house is built correctly but on unsuitable ground, the result is the same as a bad construction.

Position

Effects

HOUSES ON CLIFFS

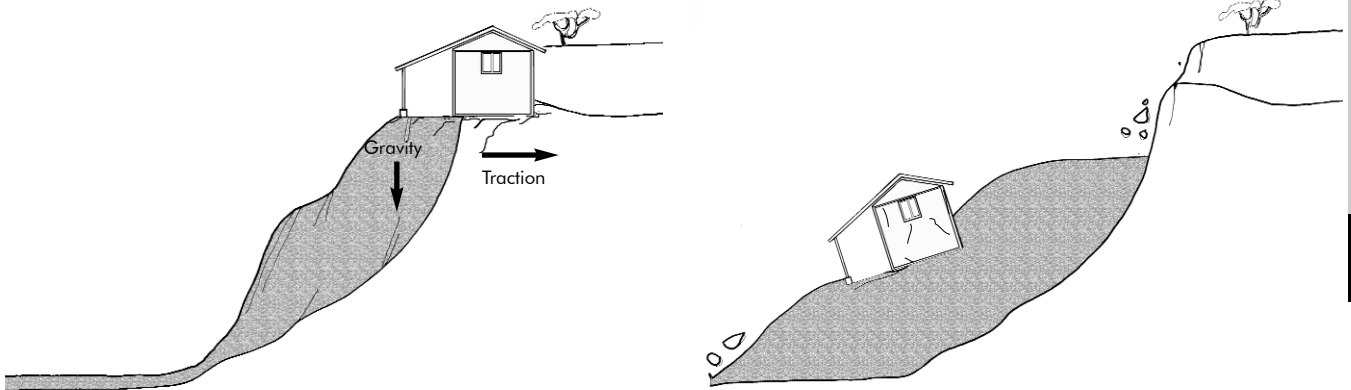

Cliffs made of soft or crumbly ground, clay loam, deposits of materials, etc. are not suitable for building houses.

HOUSES IN LOW-LYING AREAS

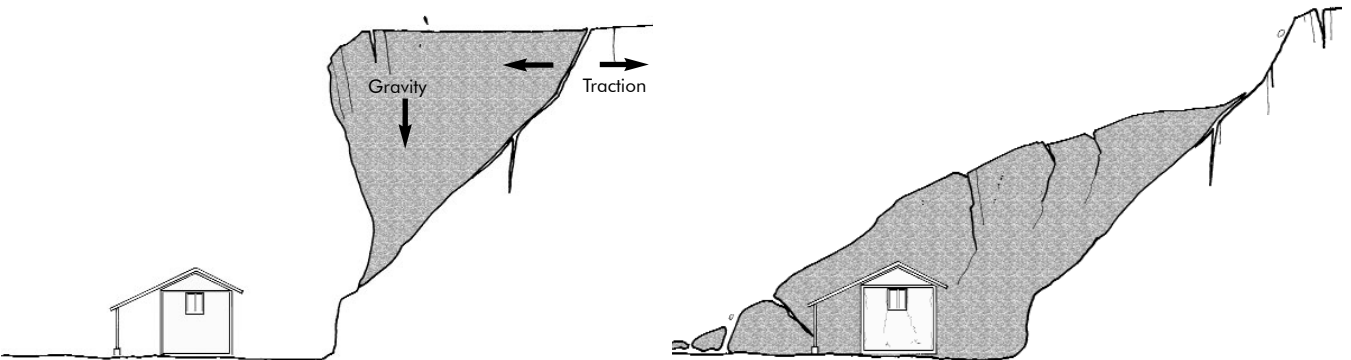

It is not advisable to build a house at the bottom of a cliff with a perpendicular face and with large crevices since these may worsen the effect of an earthquake.

HOUSES ON SOFT GROUND

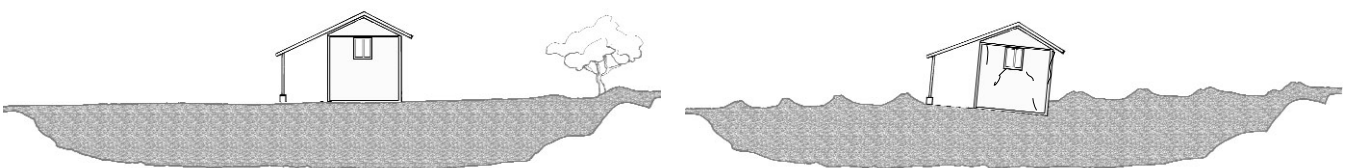

In the event of an earthquake the presence of water provokes a "liquefaction" effect leading to a total collapse of the ground ruining the construction.

EARTH AS A BUILDING MATERIAL

ORIGIN : Earth comes from the mechanical and chemical erosion of the parent rock. This rock disintegrates into mineral particles with varying dimensions from pebbles to clayey dust.

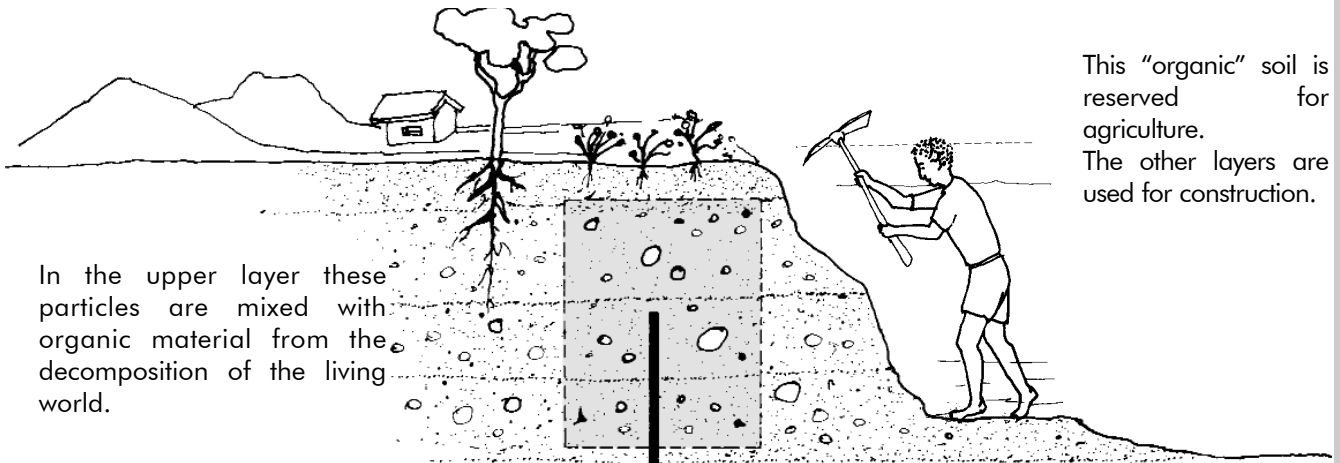

In the upper layer these particles are mixed with organic material from the decomposition of the living world.

This "organic" soil is reserved for agriculture. The other layers are used for construction.

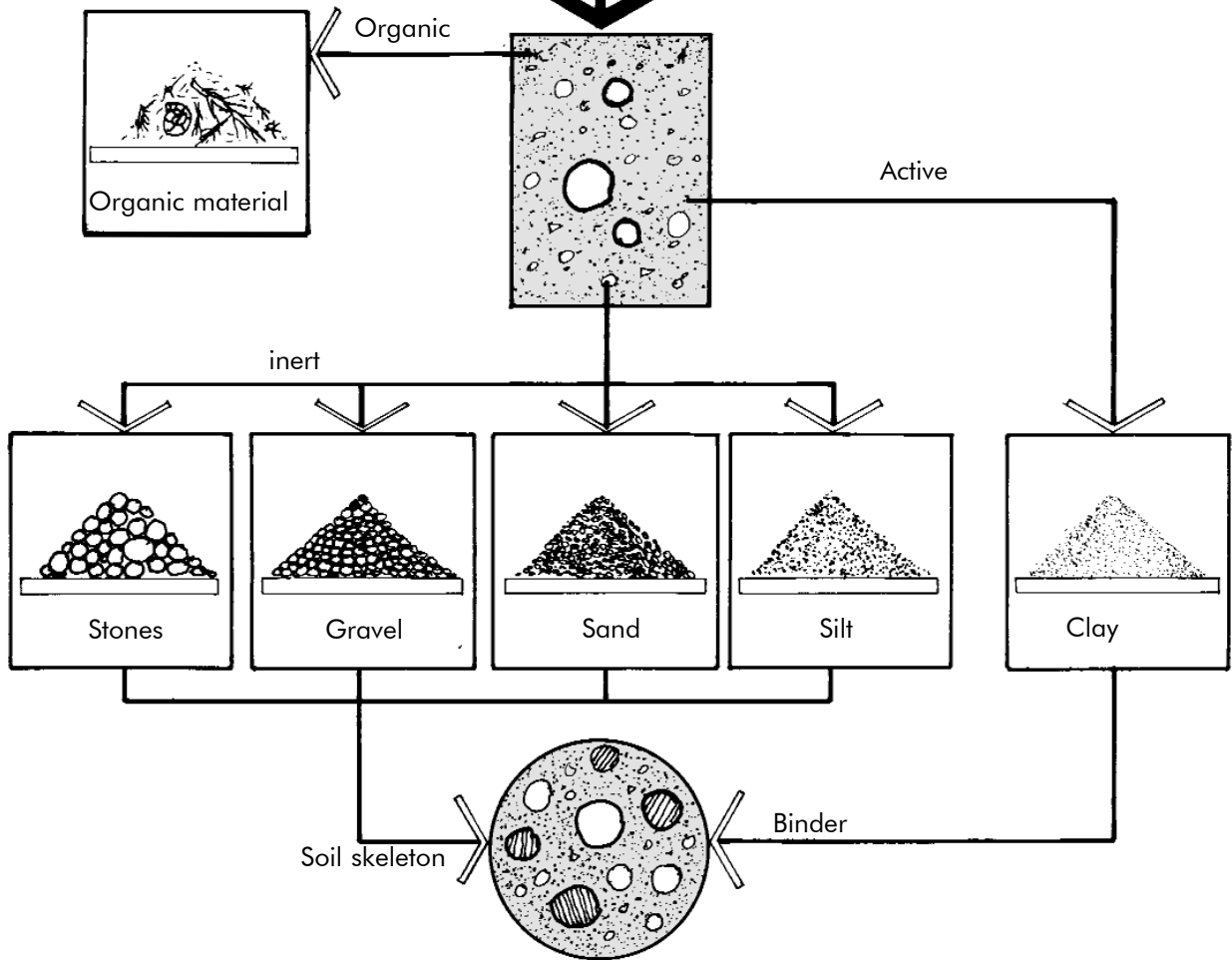

PROPERTIES OF EARTH

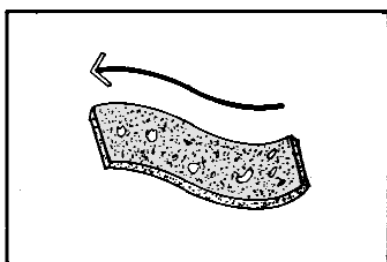

Plasticity

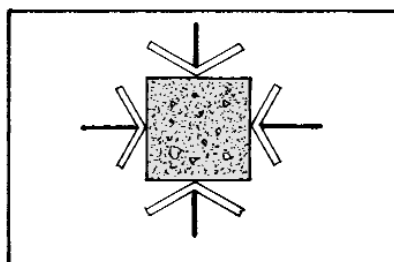

Cohesiveness

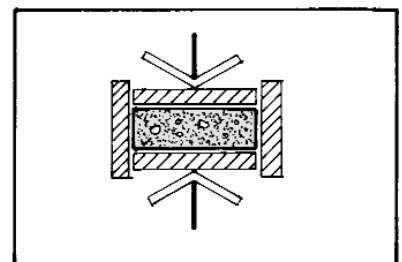

Compactability

There are several different types of earth according to the quantities of the following components:
GRAVELLY EARTH – SANDY EARTH – SILTY EARTH – CLAYEY EARTH

HYDRIC STATE, COHESION & STABILISING

HYDRIC ACTION:

As the earth absorbs water (between 20% and 30% according to the type of ground), its state changes.

There are 4 basic states:

DRY – HUMID - PLASTIC - LIQUID:

Mortar is produced in its **PLASTIC** state. This enables panels to be fitted easily since it penetrates better and will adhere to the cane.

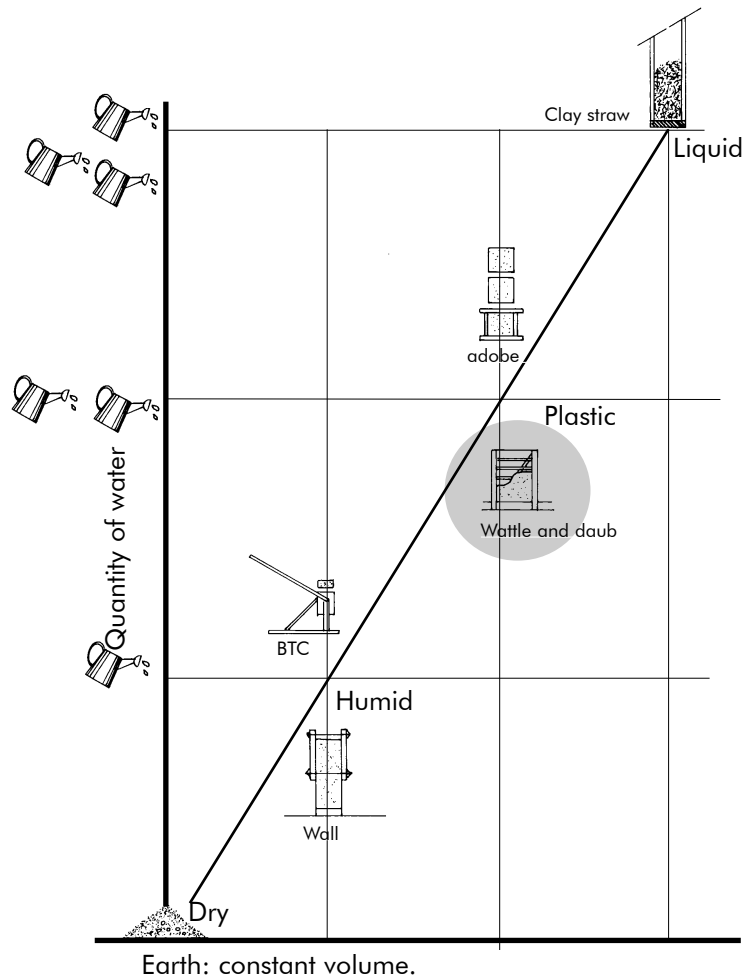

COHESION PROPERTIES

To prepare the mortar for filling the wall sections the **COHESION** property is used which works in two phases:

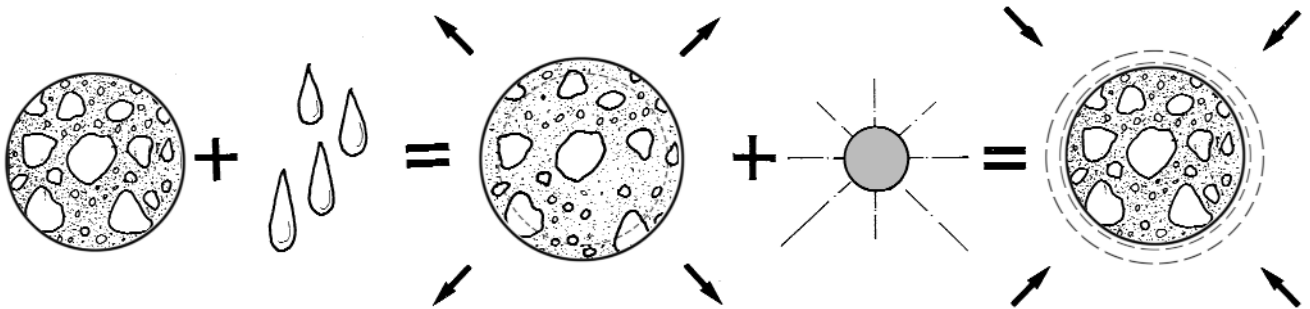

Phase 1: The earth absorbs water and the clay begins to inflate. This is a long process which requires time.

Phase 2: The earth dries, the volume of the clay decreases attracting to it the other components which are completely dry and tied.

If there are no gaps between the grains, then once dry the earth is able to resist the force of compression in the order of 3MPa.

STABILISING

When the earth is very clayey there is an excessive risk of cracking once dry, the necessary quantity has to be achieved since the presence of clay enables it to stick better between the cane:

If the earth is very clayey, it can be corrected by:

- increasing the amount of sand so as to reduce cohesion,
- mixing with straw with the aim of limiting the size of cracks.



ANALYSIS OF THE SOIL

AIM: Through simple field tests check whether the ground is suitable for producing adobe bricks. These tests show us the features of the ground. To check its components or granulometry: handling – smell, its plasticity: the “cigar” its cohesion: the “patch”. The results of these tests show us the quality of the earth.

HANDLING – SMELL



ORGANIC earth – Gives off a smell.

SANDY earth - Rough, crumbly, not very sticky

SILTY earth - Fine, easy to reduce to dust, sticky.

CLAYEY earth – Difficult to break, slow to dissolve in water, very sticky and fine.

-With water, our senses enable us to identify the main components of the earth.

CONVENIENCE:

The best is to find both sandy and clayey earth.

Take care with silty earth because once dry it does not resist water.

THE “CIGAR”



Less than 5 cm. **TOO SANDY**

More than 20 cm. **TOO CLAYEY**

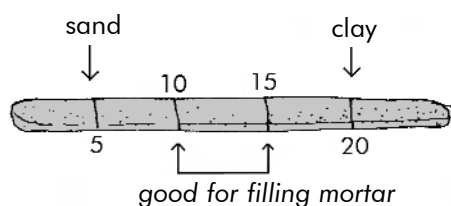

- Remove the gravel from the sample.
- Moisten, mix and allow the earth to settle for half an hour until the clay can react with the water.
- The earth should not dirty your hands.
- On a board, mould a cigar with a 3 cm diameter and 20 cm long.
- Slowly push the cigar onto one edge.
- Measure the length of the piece which comes away.
- Carry out this operation 3 times then calculate the average length .

CONVENIENCE:

Between 7 and 15 cm of good earth.

THE PATCH

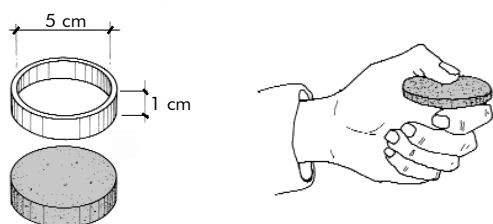

- No retraction, easy to convert to dust:

SANDY earth



- Retraction, easy to convert into dust:

SILTY earth



- Significant retraction, very difficult to reduce to dust:

CLAYEY earth



Re-use the earth from the previous test in its plastic state. Mould 2 patches using a plastic tube or similar object.

After drying:

- Observe any retraction that occurred.
- Assess the resistance of the earth by breaking and crushing between the thumb and the index finger

CONVENIENCE:

Less than 1 mm retraction, difficult to reduce to dust:
Good earth.

SUGGESTION.

Check directly on the wall section after drying outside: type of cracks, adherence and cohesion.

WOOD

Wood is one of the resources of tropical rain forests. It is the most abundant renewable resource and could help solve the housing problem.

It is physically and mechanically very resistant and is accessible for the population provided that it is used rationally.

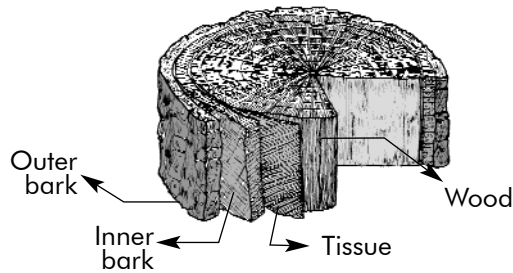

Cutting: Wood should be cut when its gum content is lowest (full moon) and during the dry season. This reduces the possibility of attacks by insects. After cutting, it should be allowed to rest with its bark on a dry floor for approximately 30 days, taking care not to bend.

Drying: After cutting, the wood must be dried to improve its technological properties and dimensional stability, and also to eliminate any remaining gum. During this process dimensional changes take place which can lead to defects in the part. Another function of drying is to obtain a product where the level of humidity is comparable to that it will acquire once used.

Drying outside on the ground in a horizontal pile

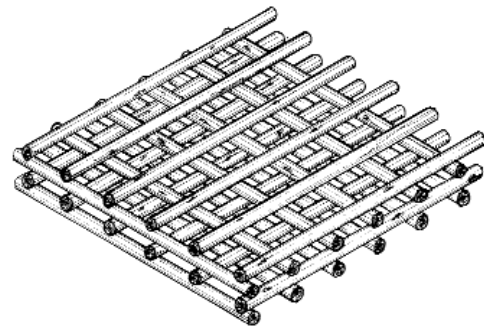

Drying outside resting vertically

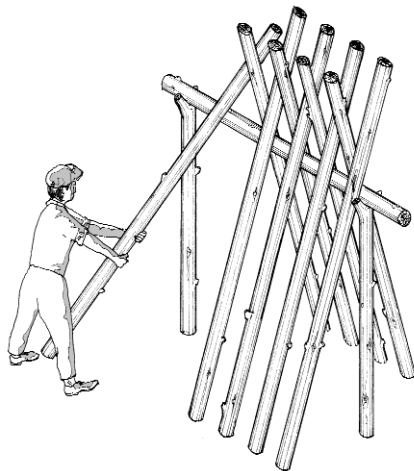

Drying methods: outside or natural drying and artificial drying

- Outside: Do not directly expose to sunlight. Place on clean, open ground with good drainage. Various forms possible : horizontal, resting vertically or by the ends.
- Artificial drying: Do not rely on natural temperature, humidity and ventilation, use special equipment (kilns). This method reduces drying time and the wood will take on very low levels of humidity

Preservation: The aim of protecting or immunising wood is to modify its chemical composition making it poisonous or repellent to biological elements. Protectors may be pure chemical composites or mixtures and must penetrate significantly. To do this the wood must be dry and already cut

Preservation methods: application or by pressure.

- application with a brush, spraying, immersion, hot or cold bath.
- by pressure the protector is applied using pressure different from that of the atmosphere using an autoclave.

Terminology for use

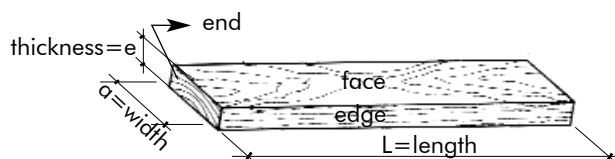

1 foot = 12 inches = 30.48 cm

1 inch = 2.54 cm

Preservation method by immersion

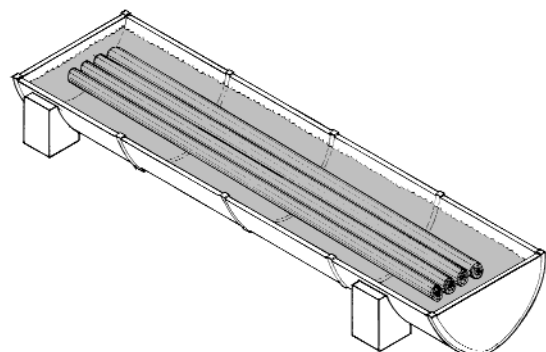

POLES - Cane / Bamboo

Classified in botanics as **graminae** or grass, these species with vertical, cylindrical and hollow stems provide a series of physical and mechanical features which enable them to be used in construction.

It is an accessible material and easy to work with simple manual methods.

Cutting. The most suitable time: during the dry season, waning moon and adult age depending on the species

Recommendations for cutting:

- Cut between 30 and 40 cm above the ground and after knots.
- If to be used as part of the structure cut when adult.
- Cut "cleanly" so as not to damage the stem, use a sharp instrument.
- After cutting a period of preparation is required during which the gum will be removed from inside the stem. To do this you will need to leave the sticks in the field where cut vertically, without removing any branches and avoiding contact with the ground, between 4 and 8 days.

Outside drying resting vertically

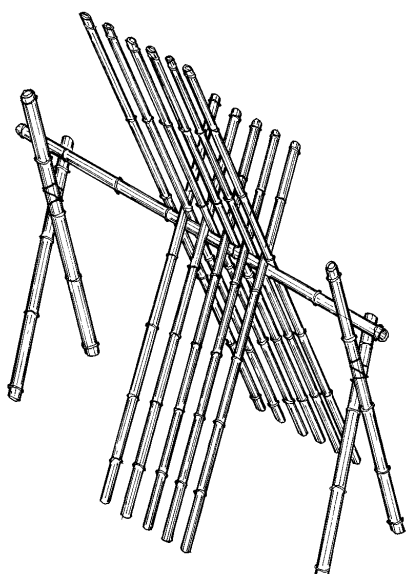

Drying: Needed to avoid deformations, cracks, and dimensional changes. Living organisms cannot live in cane with a level of humidity below 15%. The resistance properties increase in cane with a low level of humidity.

Can be dried outside or under a roof with open walls, for 60 days, also using a heater or an open fire (2 to 3 weeks), taking care to keep under control so as not to make the wood crack.

Outside drying in a pile

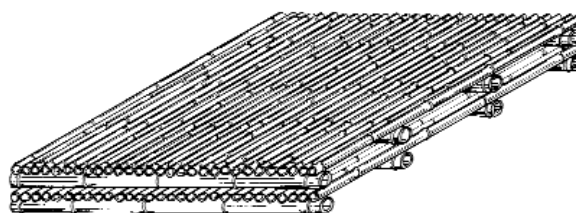

Preservation: Gives the sticks durability. Consists of taking advantage of the spaces between the inside fibres to deposit germicides, fungicides and insecticides for exposed poles, for poles embedded in the walls you will only need to eliminate any starch and sugars which may remain inside.

To do this there are several possible methods:

- By immersing in a preservative solution (salt, lime or hot asphalt) for 5 hours or simply in clean water for a month, changing the water every day.
- "Boucherie" procedure tying the stems to a high deposit with preservative.
- Filling the stems, filled in on one end, with preservatives.

Preservation method by immersion

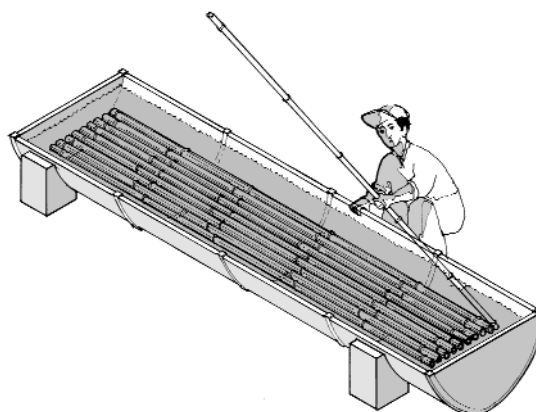

Shapes for cutting bamboo into strips.

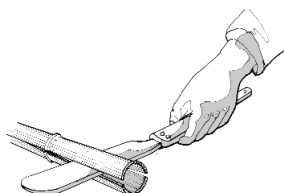

cutting with a machete

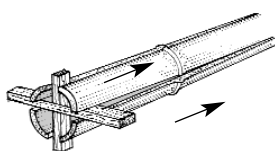

hard wood crosspiece

Most widely used species in construction in Central America

- *Arundo donax*
- *Gynerium sagittatum*
- *Phragmites communis*
- *Guadua angustifolia* (including bamboo cane)
- *Chusquea* spp

SETTING OUT

The first operation carried out when beginning to build the house consists of tracing out the design on the ground. It is important the house is correctly traced out since this will condition the success of the following steps of construction.

1- Vertical level. Using a transparent hosepipe and water:

- check the % of difference in ground level
- set the height of foundations
- transfer the heights from one side to the other.

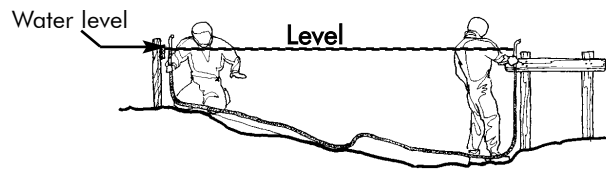

2- Tracing out. Once the ground has been prepared: clean and level out. Using temporary stakes and string trace a line AB which we shall refer to as the "master" or reference line.

To trace the orthogonal line CD (right angle) to the "master" line, use the 3,4,5 method, ie. make a right angle using a decametre.

Situate the cross point, set point D and draw the string towards point E aligning the previously defined right angle.

The next orthogonal line EF is traced out in the same way as above.

Finally, line GH parallel to the master line, before taking the required distances.

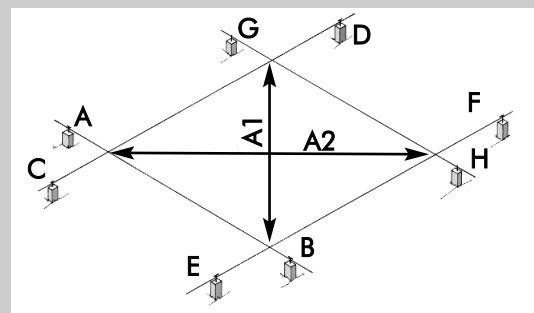
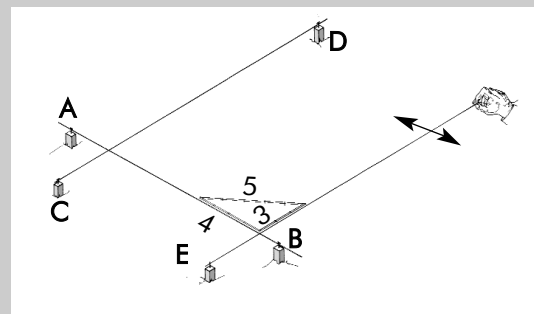
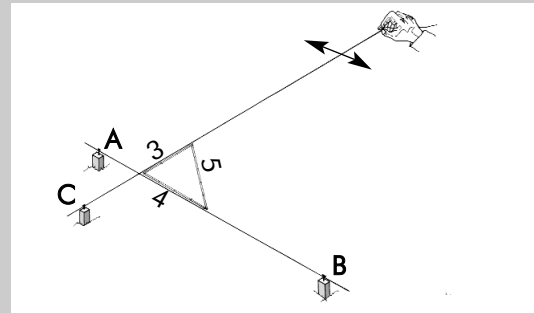

Fitting the stakes and barriers

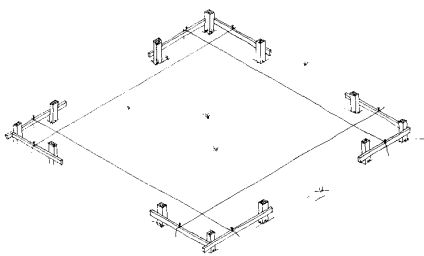

Once the area has been demarcated, check if the angle is correct on all 4 sides by measuring the two diagonals $A1 = A2$.

Width of foundations

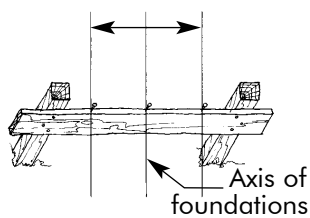

Then fit the definitive stakes with the aim of defining the axis and width of the foundations and the wall with the house's definitive dimensions.

Marking out the limits of the trench

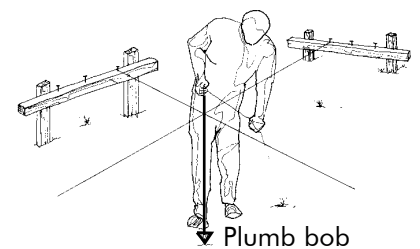

The points are then marked out on the ground for tracing out and digging, using a plumb bob and string

FOUNDATIONS

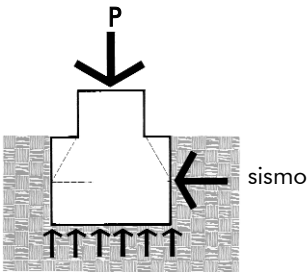

The purpose of the foundations is to transfer the load of the construction onto the ground. The weight of the structure must be suited to the load capacity of the ground which must furthermore be stable. The structure must also be correctly joined and anchored to the foundations.

PROBLEMS - PATHOLOGIES: inadequate foundations

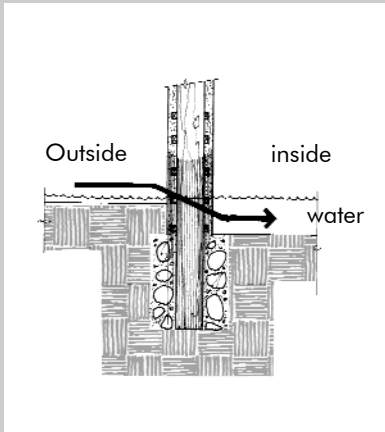

Flooding

The foundations need to be solid and the wall base must be approximately 20cm above the level of the ground on the outside in order to avoid:

- the wall absorbing humidity when it rains.
- flooding if the level of the inside floor is lower than outside.

If the above occurs the walls will be weakened and will easily collapse the event of an earthquake

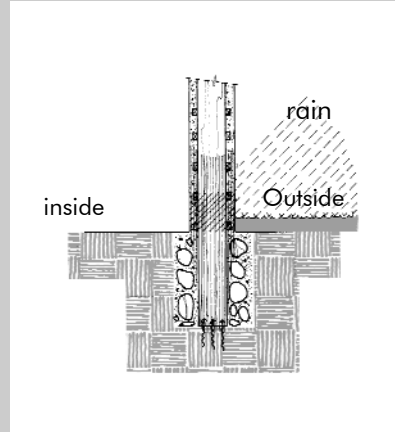

Absorption of humidity

TYPES OF WALL BASE & FOUNDATIONS

The type of material used for the foundations will depend on the availability of material, its cost and implementation time.

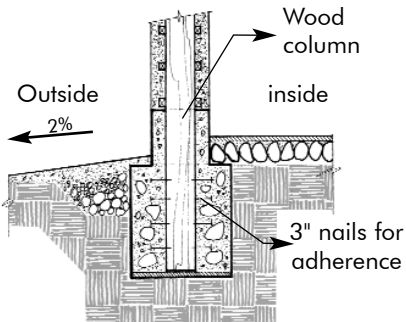

Foundations: column embedded in the concrete.

The minimum width of the foundations will be 40cm. Nevertheless it is advisable to use a ratio 1.5 times the width of the wall.

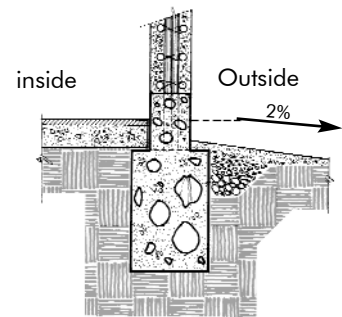

Foundations Cyclopean concrete

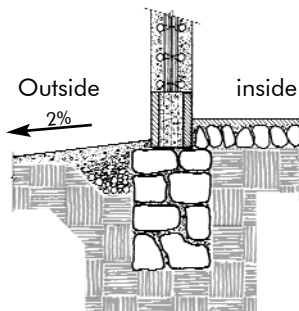

Wall base with concrete blocks (39x19x14cm) or similar material and concrete filling.

The minimum height will be 20cm.

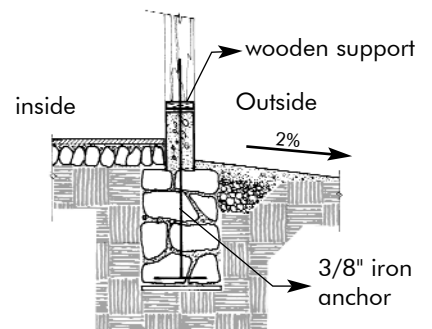

Foundation with wooden column fixed to the concrete wall base.

STRUCTURE & FILLING - Traditional Wattle & Daub

Traditional wattle and daub consists of a structure made from cylindrical wood or bamboo (guadua) filled with earth and straw inside a double structure made from bamboo strips or thin canes.

Corner junction

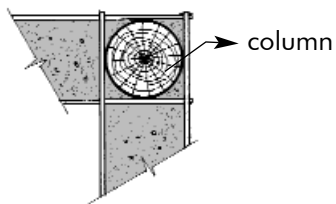

"T" junction

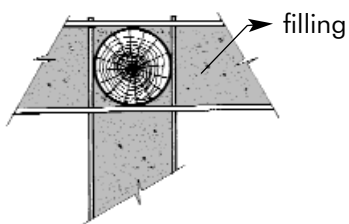

"+" junction

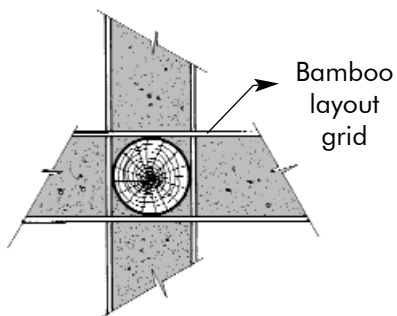

Details of the wall structure

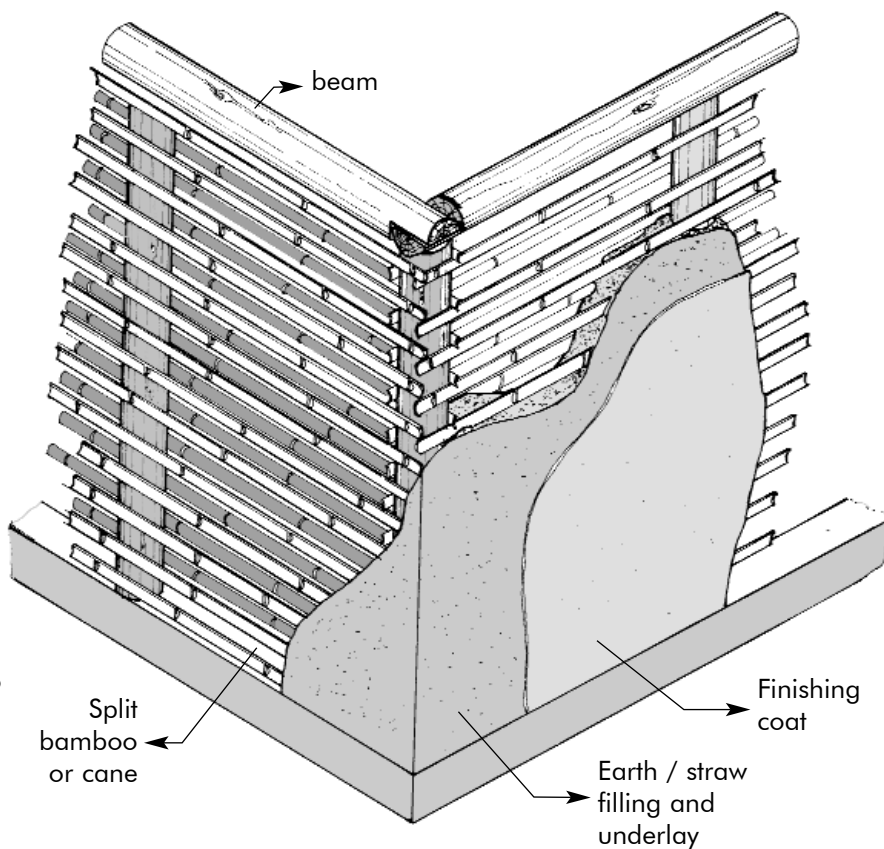

Standard elevation for wall

120 - 150 m

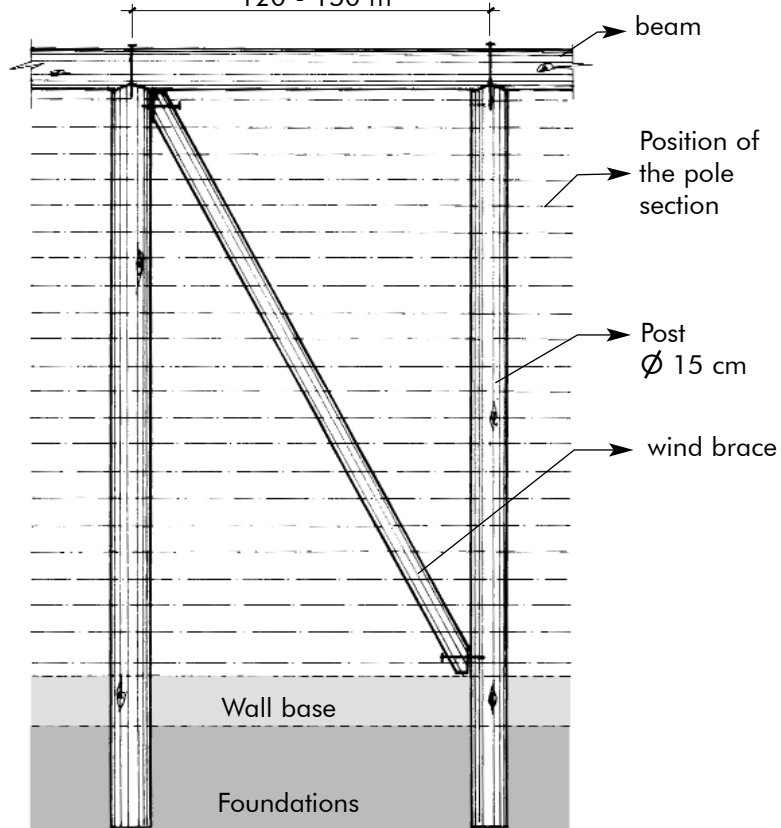

Details of the support-column

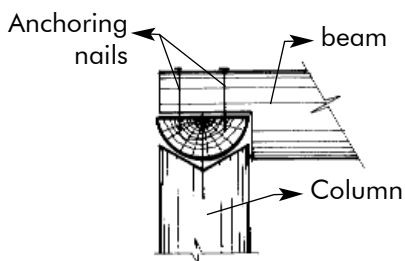

Wall cross-section

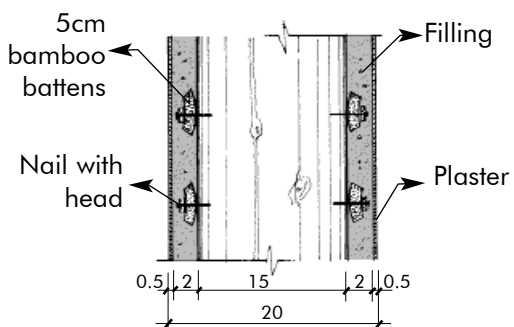

STRUCTURE & FILLING - Conventional Wattle & Daub

This type of wattle and daub is a more modern version of traditional wattle and daub and is the most widely used. It has sections of cane or bamboo poles fixed with wires and nails to a sawed wooden structure which enables a better finished assembly.

Corner junction

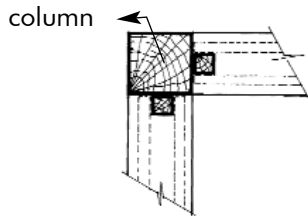

"T" junction

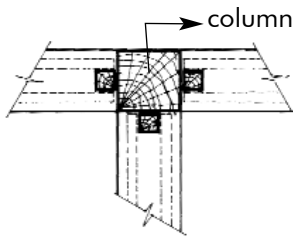

"+" junction

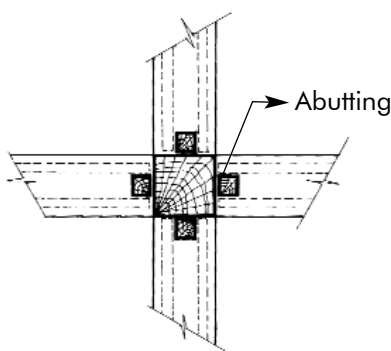

Detail of the wall structure

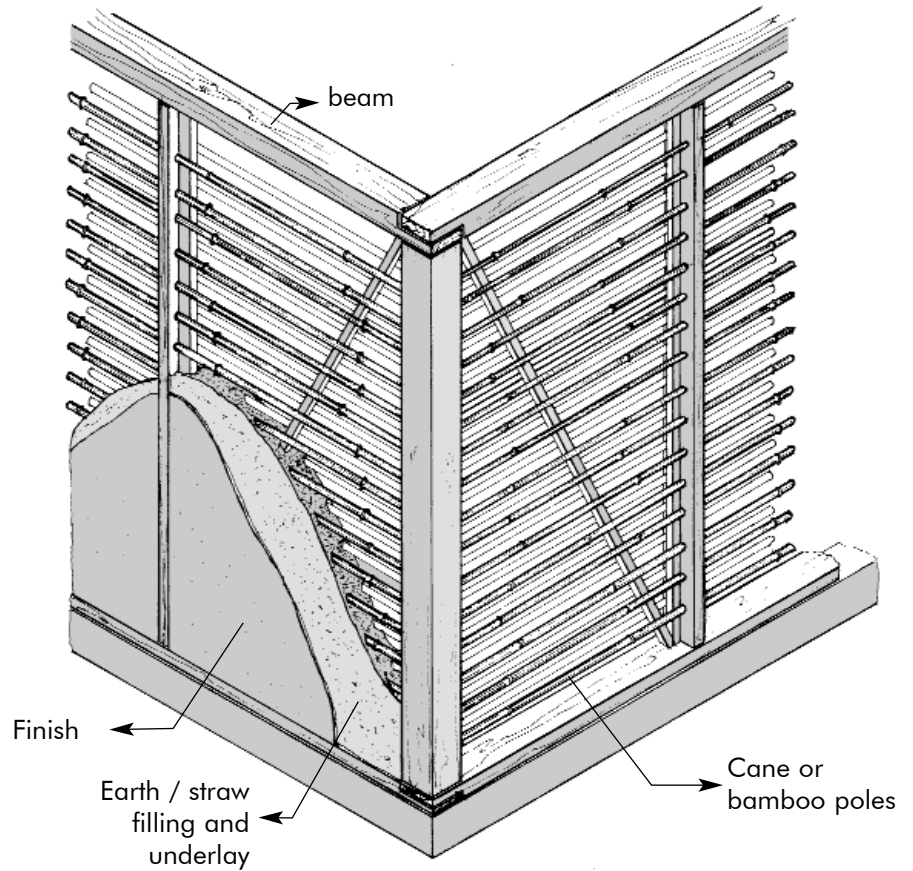

Standard elevation for wall

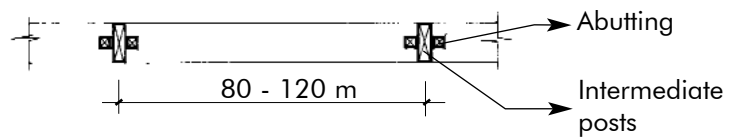

Detail of cane fastening

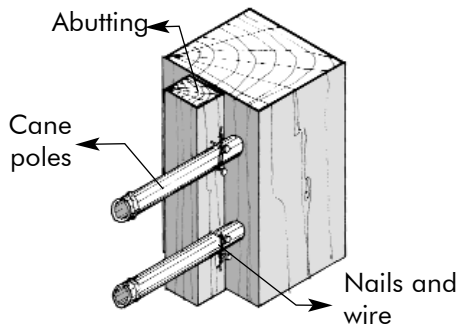

Detail of anchorage of lower plate to foundation

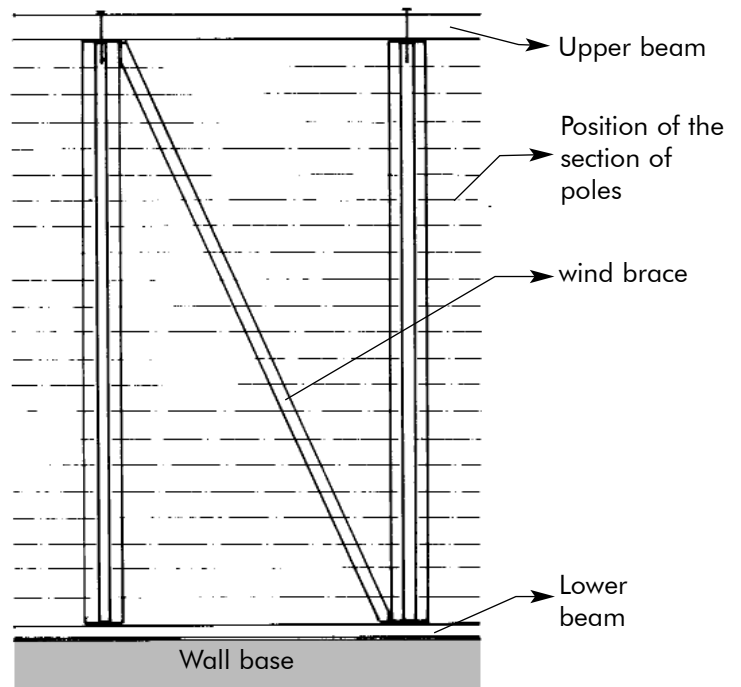
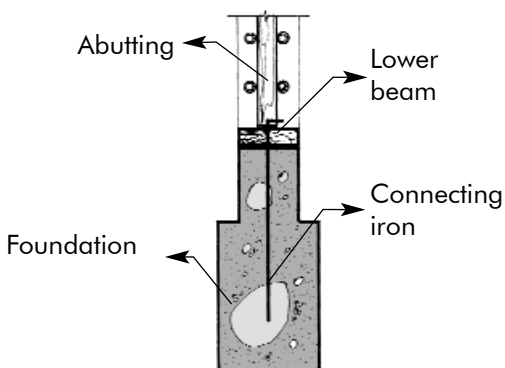

STRUCTURE & FILLING - Prefabricated Panels

The "Quincha" prefabricated panel is a sawed wooden frame, filled with interwoven cane or bamboo battens, inserted in such a way that they are self-anchoring. After being assembled these panels are walls which will be plastered with earth and straw mortar with an initial layer and then a thin finishing layer. The advantage of prefabricated panels is that they enable the panels and the structure that will carry them in the wall to be made at the same time, thus reducing assembly time

Inside wall junction

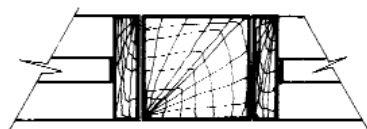

Corner junction

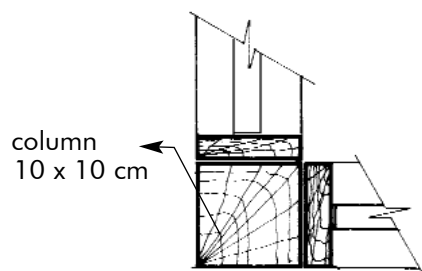

"+" junction

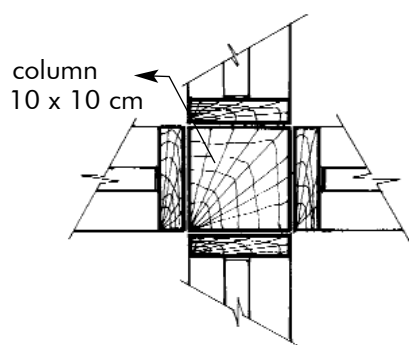

junction between panels



Detail of the anchorage of panels to the foundations

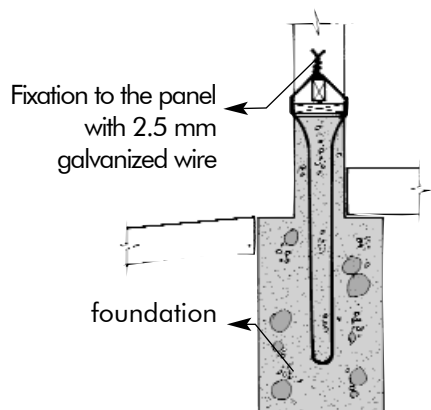

Detail of the wall with prefabricated panel

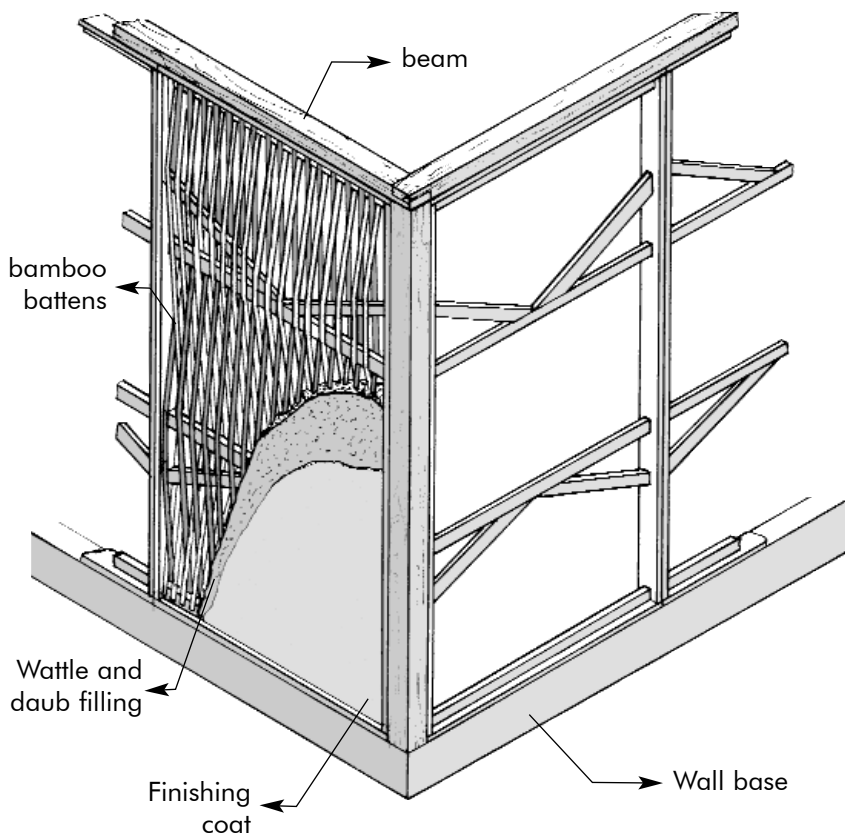

Standard wall panel

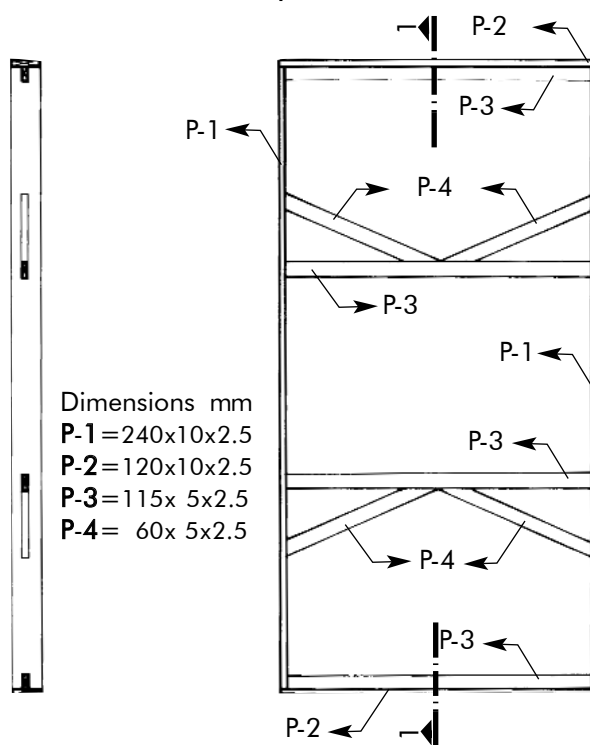

Dimensions mm
 P-1 = 240x10x2.5
 P-2 = 120x10x2.5
 P-3 = 115x 5x2.5
 P-4 = 60x 5x2.5

Cross-section 1-1

Elevation

ROOFING STRUCTURES

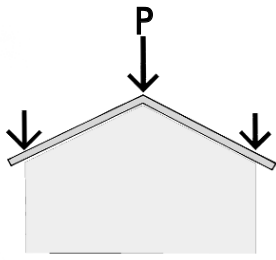

The roof: the structure and cover behave like a diaphragm (rigid and flexible) which resists flexion and breaking.

A house in an area prone to earthquakes requires a light roof which distributes its load evenly on the walls.

The eaves also need to be considered part of the wall's protection and should neither be less than 50cm nor greater than 1m.

TYPES

MICRO-CONCRETE TILES

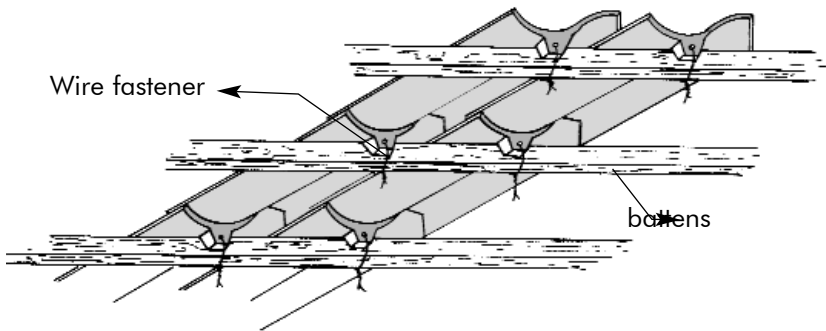

Micro concrete tiles better insulate the inside environment from heat and the noise of rain.

However they require a uniform structure and a greater number of battens.

12.5 units of tiles are needed for one square metre of roofing.

Lateral installation

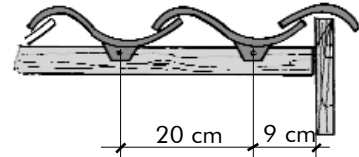

Detail of overlap and anchoring

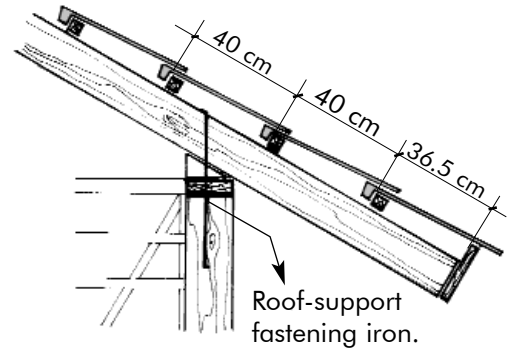

CORRUGATED PANELS

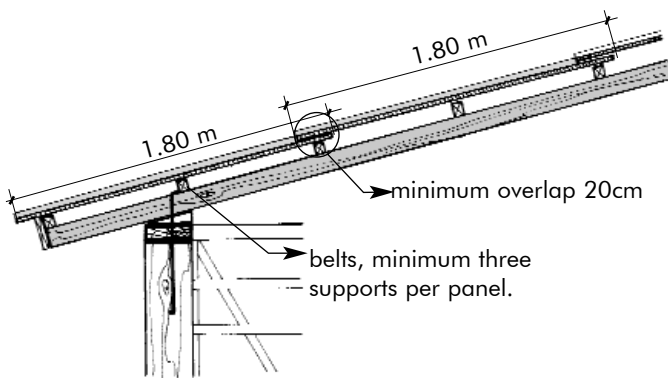

Overlapping and securing

On roofing sheets with small corrugations (25mm) the overlap is one full undulation in the direction of the wind.

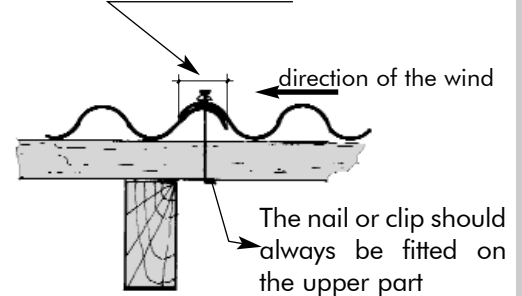

Lateral overlapping

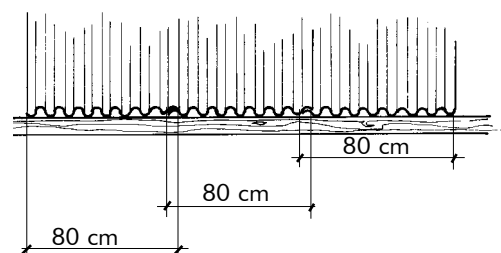

Corrugated sheets, (Zinc) are easy to fit onto a house and are also economical, but they let heat and noise in. Once it is perforated the entire panel needs to be replaced.

For a 1.20m² roof 1 panel is required.

PLASTERING

Treatment applied to the surface of the wall with the aim of protecting it against the weather and use. Also used to make the house more aesthetic.

A wall protected by facing will be in better conditions in the event of an earthquake

Plastering includes several steps:

1. Preparation:

Clean the wall in order to eliminate any loose soil or sand, to guarantee the adherence of the plastering to the wall section. If the wall is wet, you should wait a while so that any water inside the wall can evaporate and be absorbed

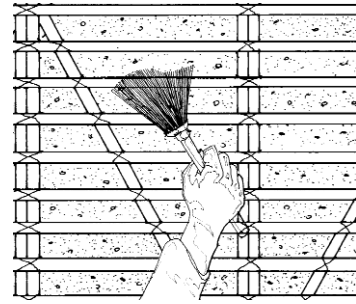

2. The underlay:

Used to level out the wall's imperfections and so it can receive this finishing layer.

The thickness of this layer will be between 8mm and 20mm.

The mortar must have the following proportions:

1 part of earth at 5mm diameter.

2 parts of sand (which go through the 5 mm mesh)

1/3 of straw cut into 3cms strips.

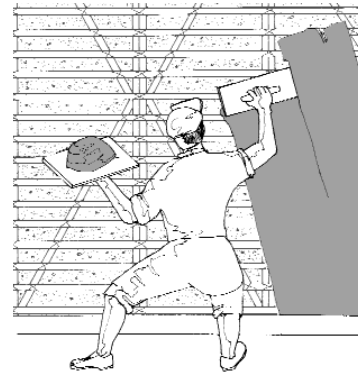

3. "Incisions"

Before the first layer, dries, "incisions" are made using a metal brush or nails. This improves the adhesion of the second layer onto the first.



4. The second layer: "the finish".

An aesthetic thin seal or protective layer, added once the first layer is completely dry.

The thickness is between 1 and 2mm.

The mortar will approximately be:

1 part of earth (which goes through the 2mm mesh)

3 or 4 of fine sand.

When making the plaster it is important to test different mixes, changing the proportions until the right mix which does not crack and which is resistant is achieved.



5. Sealing

Use a sponge making circular movements then wait for between 15 and 20 minutes before using a dry paint brush in straight movements, the aim is to seal the surface.

Alternatives: there are other alternatives and combinations.

Lime and sand,

Lime, sand, earth,

Chalk and sand,

Chalk, lime and sand

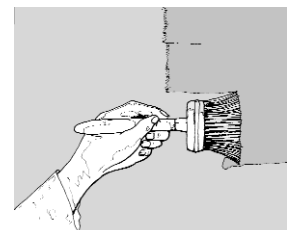

Appendix

CEREN REINFORCED WATTLE & DAUB HOUSE

This proposal is based on an ancestral technique developed by the former inhabitants of the so-called Joya de Ceren in El Salvador. Archaeological remains are witness to their presence, where we can examine the building forms and techniques used.

As a result of his visit (1995) to this archaeological site, the author decided to develop a new proposal based on the building techniques of this civilisation and adapt them to contemporary methods and materials, especially bearing in mind the earthquake factor. Later on, the first experiments were carried out at the CRATerre research centre in France.

In 2001 a prototype called "La Semilla " was created within the framework of the "El Salvador house reconstruction programme" under the responsibility of MISEREOR and FUNDASAL. The advantages and efficiency of this system were examined on the field system, which may solve housing problems, were.

One of the features of this proposal is to eliminate wood, (thus avoiding cutting it down indiscriminately) to make the house structurally resistant and easy to build. This proposal is known as "BAHAREQUE-CEREN" in honour of the pre-Hispanic culture and to be witness to the continuity of a building culture.

Arch. Wilfredo Carazas Aedo

DEVELOPMENT OF "LA SEMILLA"

The dimensions of the house were developed using a model known as "La Semilla", which satisfies anti-seismic conditions. The successive enlargements were developed from this model.

The size and growth of the house will depend on economic conditions, availability of materials and time. If these conditions already exist we can go directly to the last step.

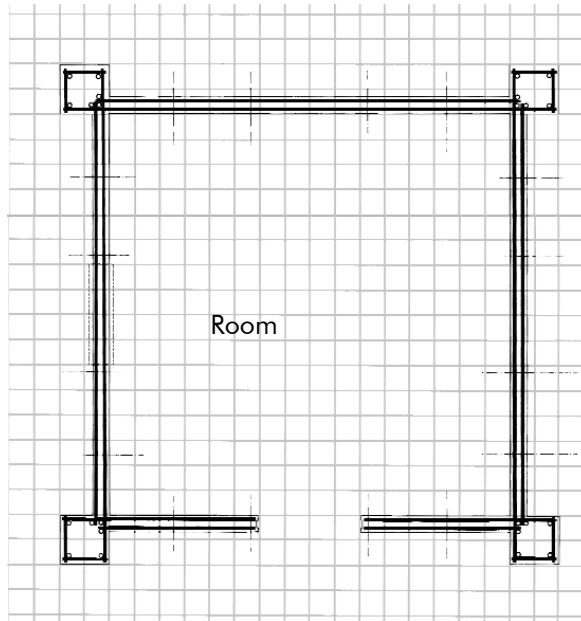

LA SEMILLA
Living area = 10.24 m²

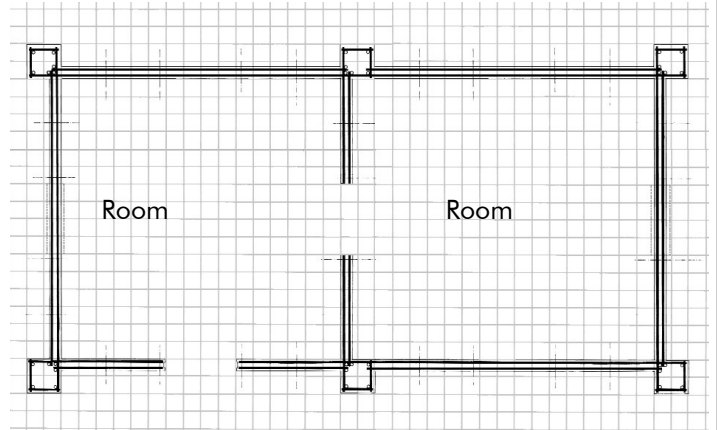

BASIC RURAL HOUSE
Living area = 21.28 m²

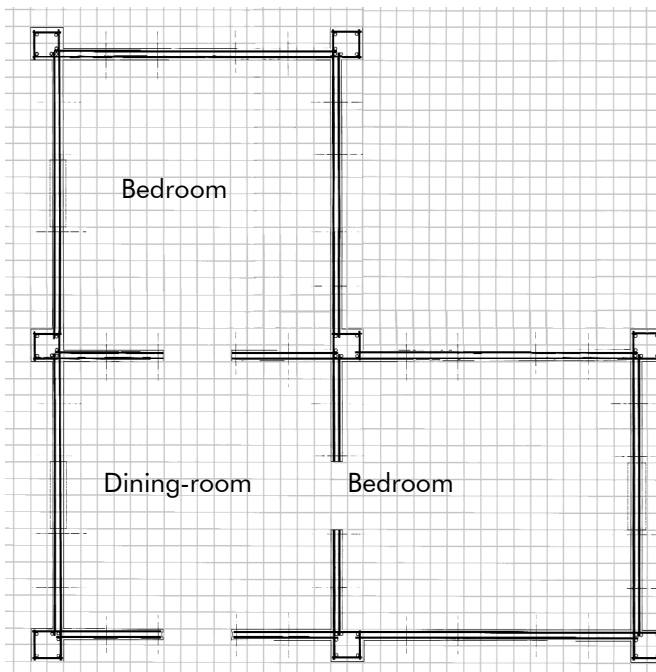

INTERMEDIATE HOUSE
Living area = 32.32 m²

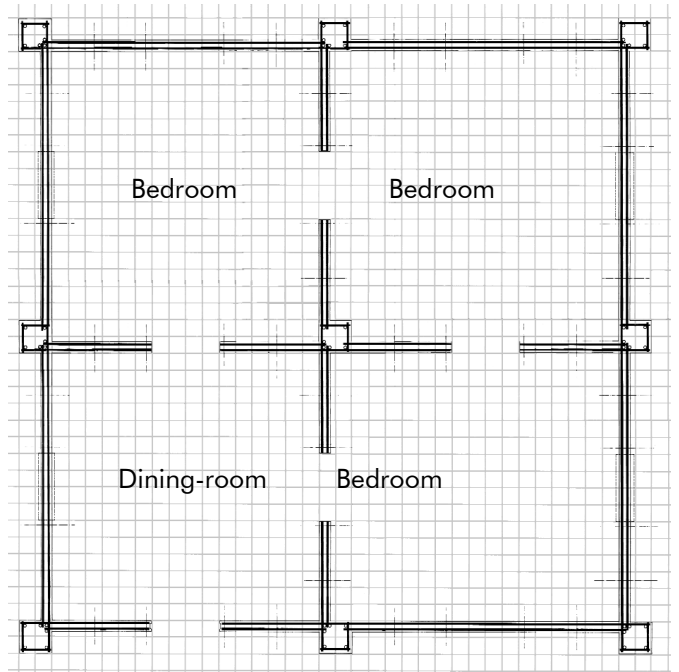

COMPLETE HOUSE
Living area = 44.2 m²
IMPORTANT. The area for cooking is not considered because traditionally it is located in an annexe. If conditions are favourable "La Semilla" can be considered as a kitchen.

NOTE:: These forms are not the same as a rectangular or "L" shaped house. Here it is the sum of models correctly supported.

GROUND PLAN FOR FOUNDATIONS & WALL BASE

After laying the foundations and fitting the columns, the wall base is made which will consist of one layer of hollow concrete blocks. The vertical supports are then fitted at the given distances.

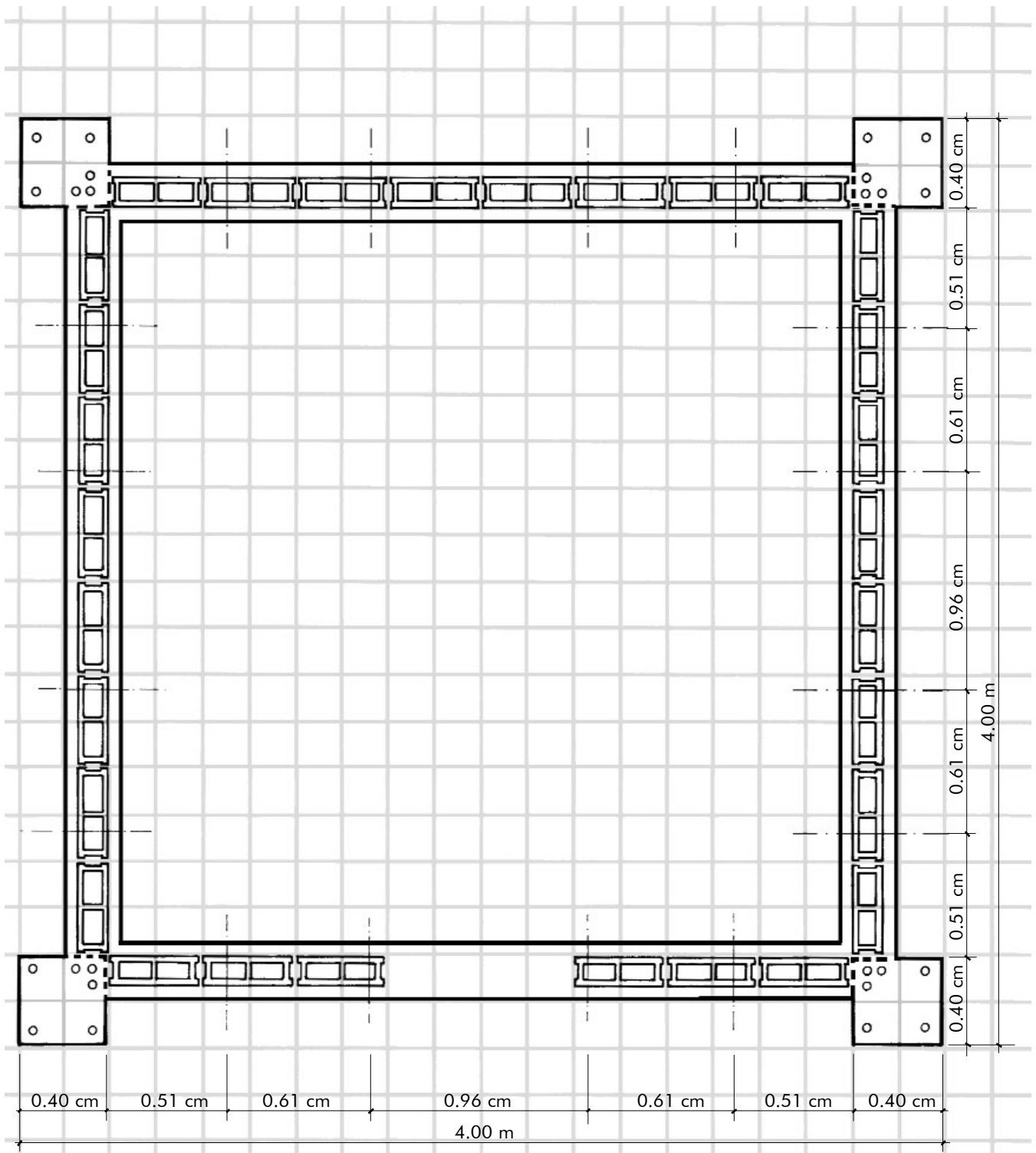

Quantity of blocks 39 x14 x19 or similar = 30 blocks per cell
The cyclopean concrete foundations will be 25 cm wide x 40 cm high

GROUND PLAN FOR THE POSITIONING OF POLES

To make the next part more comprehensible, we have classified the poles according to their length, followed by the quantity needed for each cell

Horizontal poles		
	Quantity	Dimension
V-1	80 poles	3.98 m
V-2	80 poles	3.36 m
V-3	40 poles	1.78 m
V-4	40 poles	1.24 m
V-5	200 poles	0.38 m

Vertical poles		
	Quantity	Dimension
V-a	8	2.30 m
V-b	12	2.60 m
V-c	4	2.41 m
V-d	4	2.53 m
V-e	4	2.80 m

Vertical poles		
V-f	4	2.92 m
V-g	8	3.10 m
V-h	12	3.40 m

Contravientos:	
Quantity 60	Dimension 0.90m

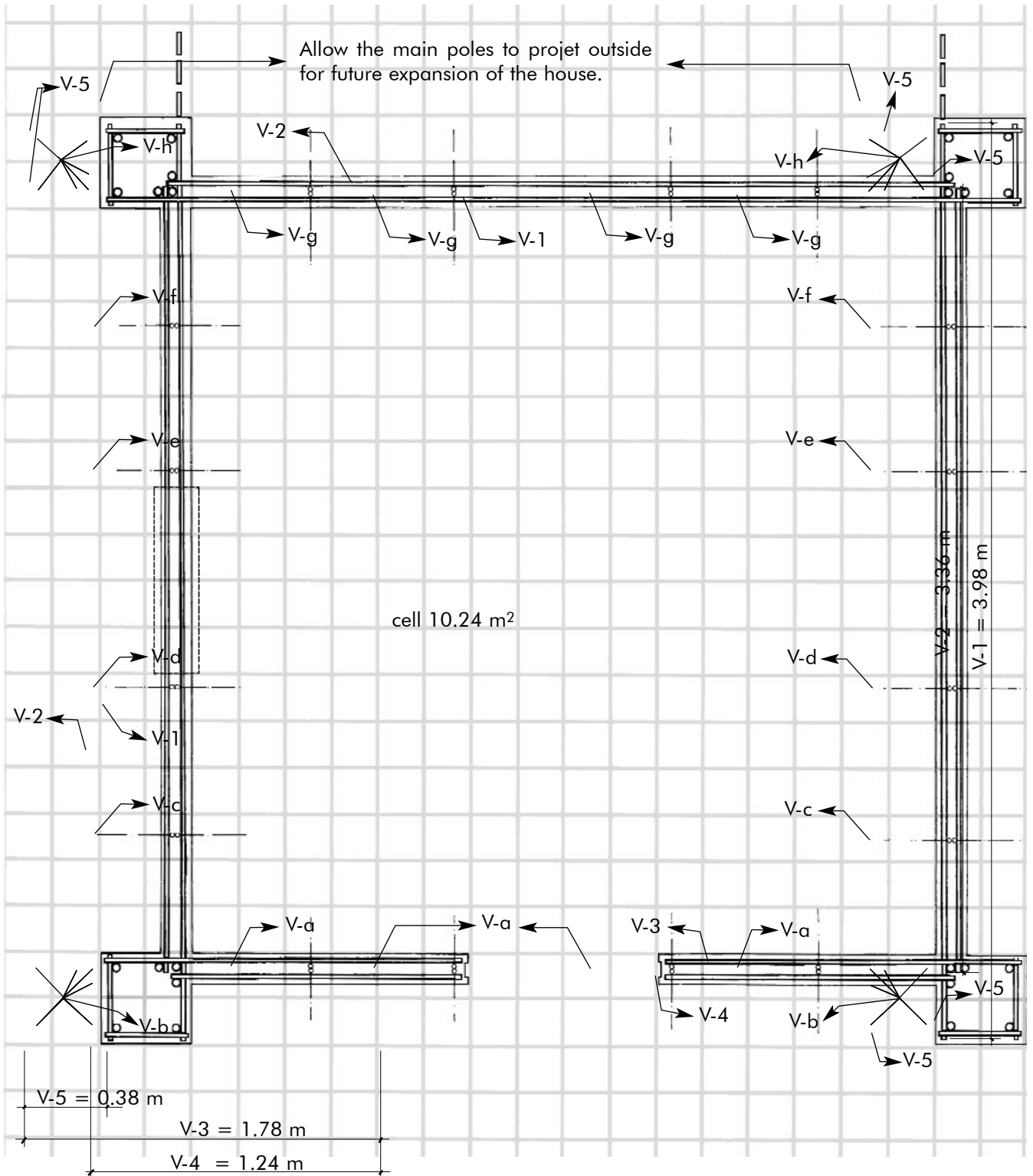

ELEVATION & CROSS SECTION

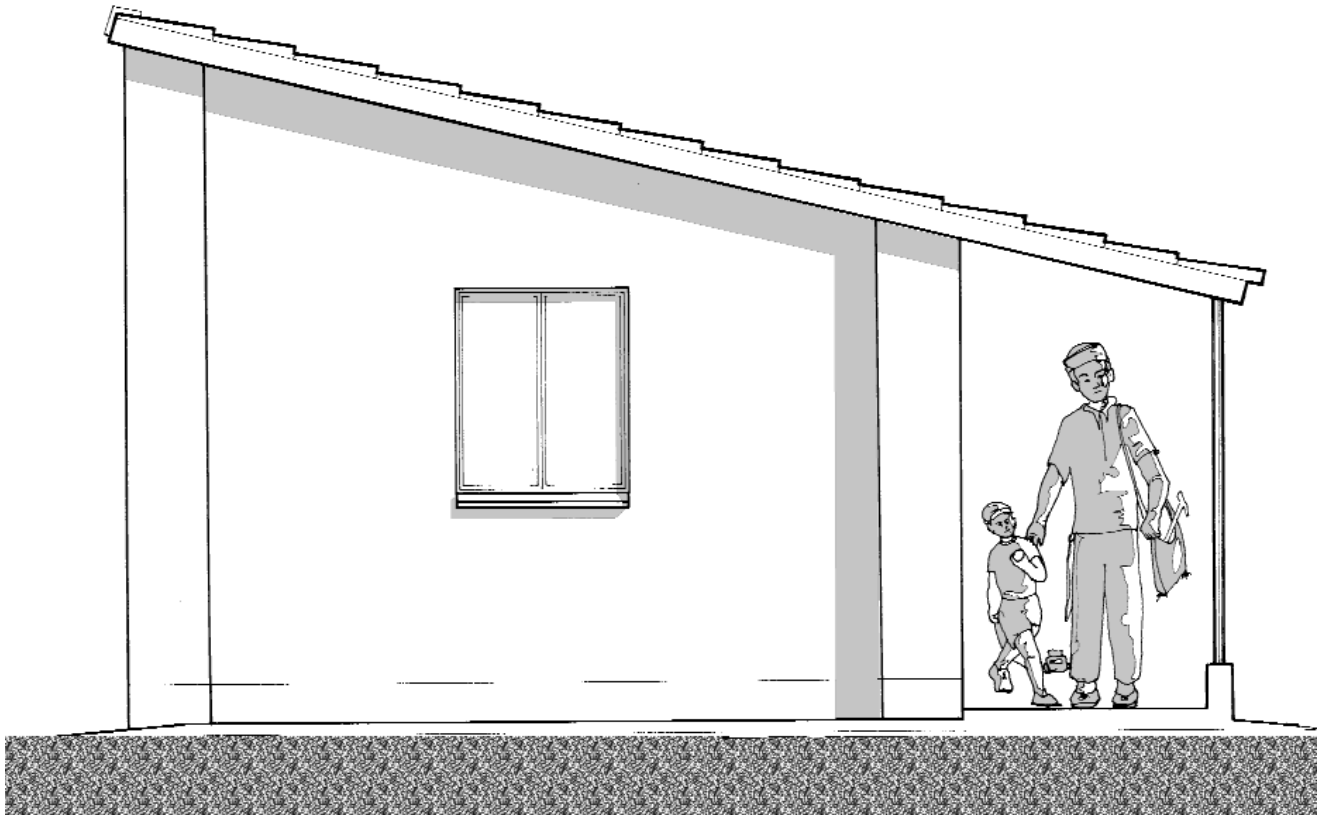

LEFT LATERAL ELEVATION

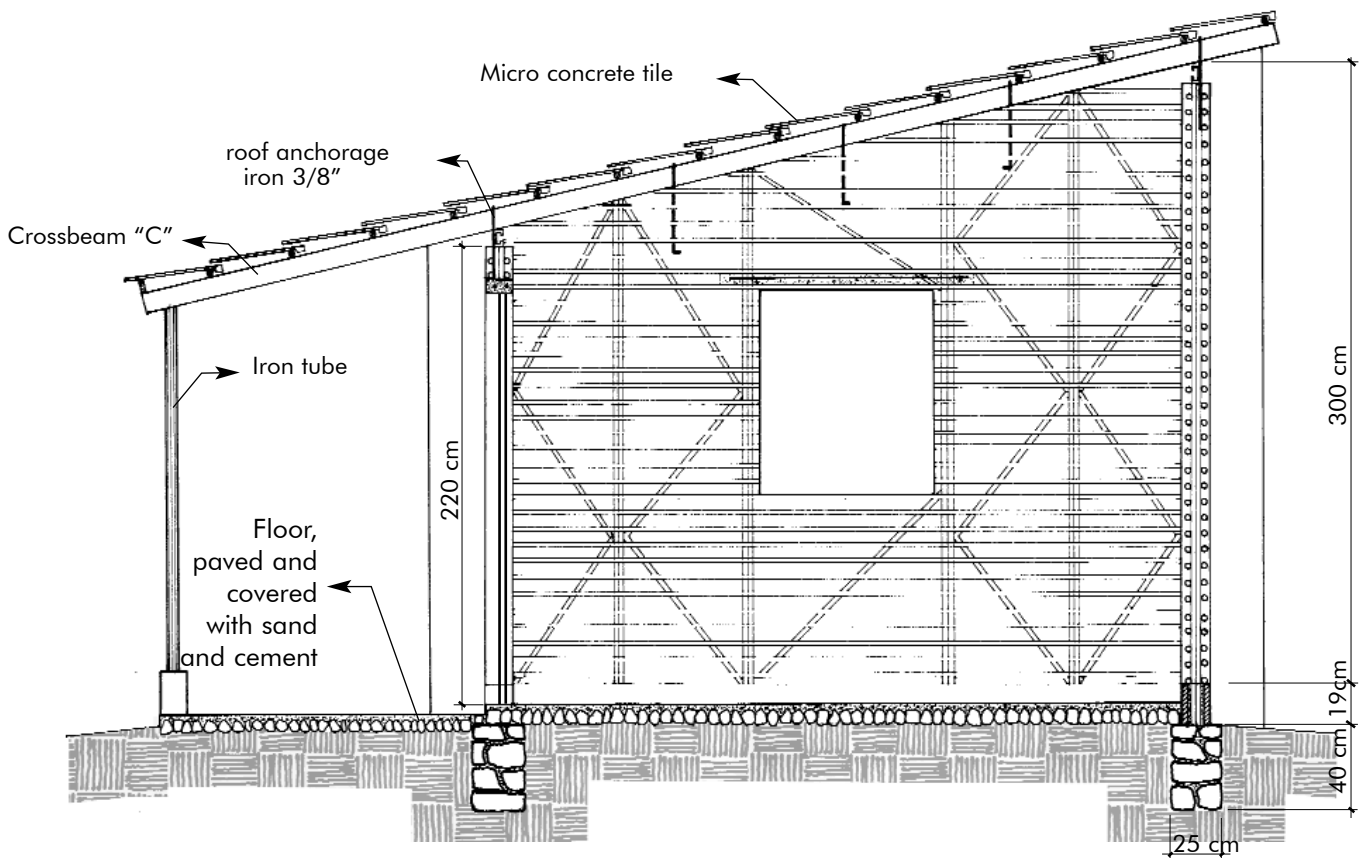

CROSS SECTION A-A

FARMHOUSE WITH 21.28 M2 LIVING SPACE

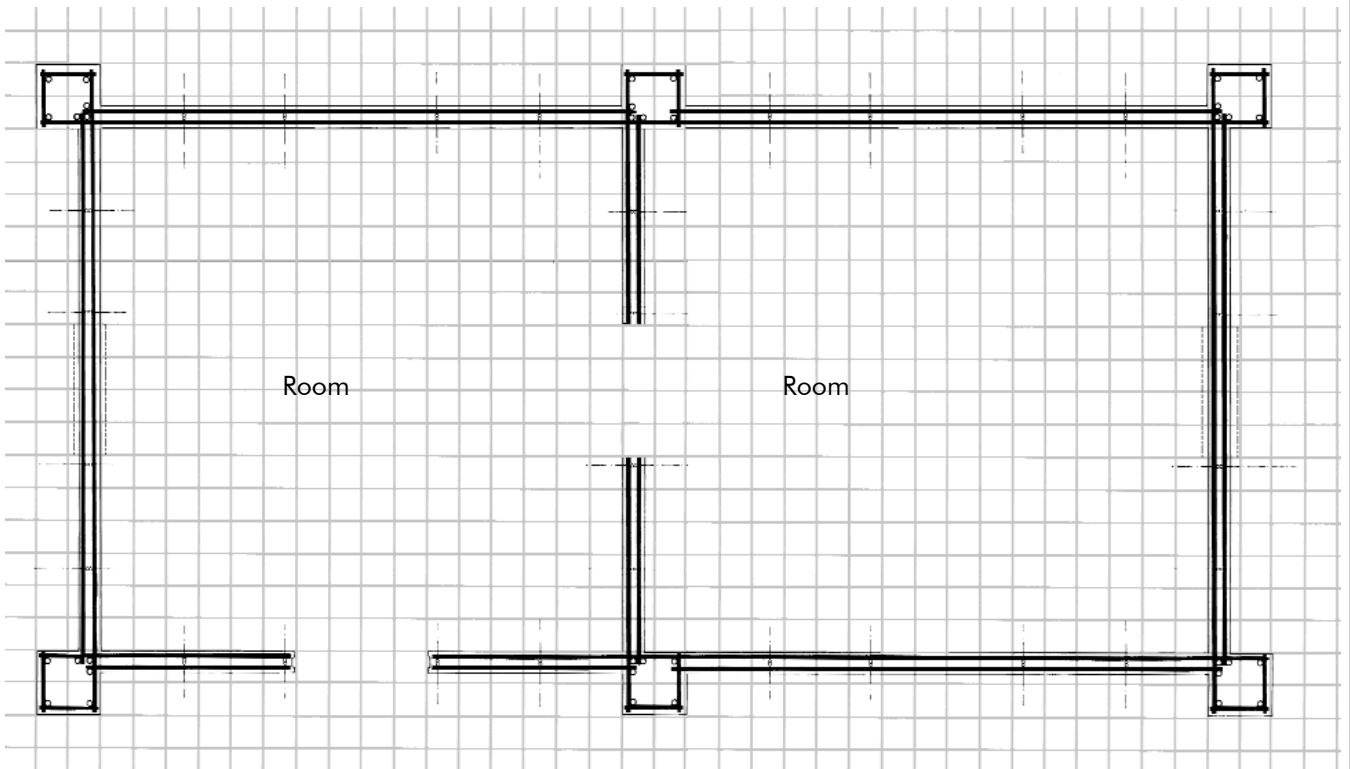

GROUND PLAN OF THE HOUSE

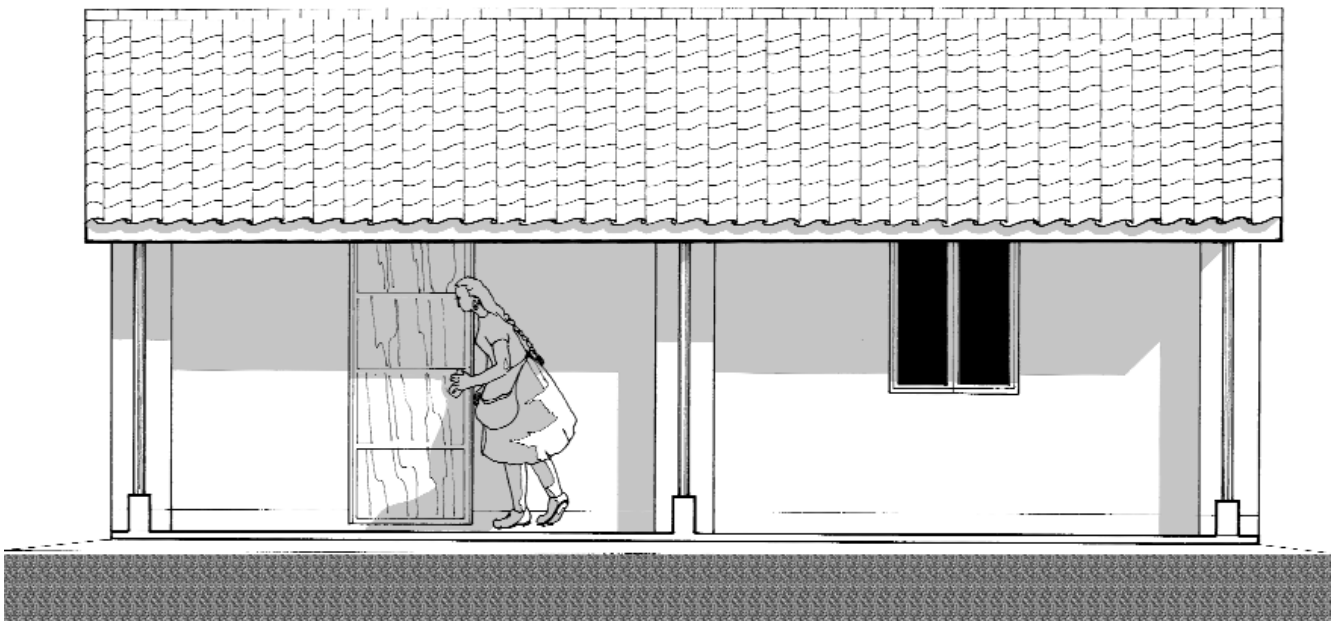

ELEVATION

CONSTRUCTION DETAILS

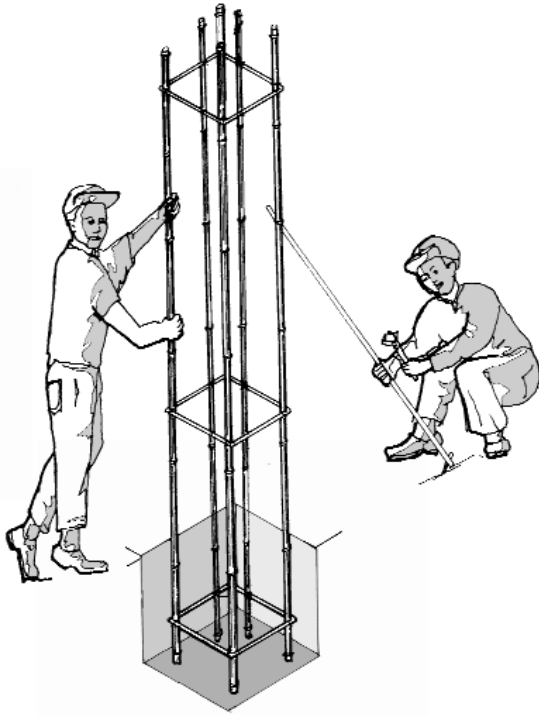

To set the columns use a plumb to make sure they are vertical, hold them temporarily with braces.

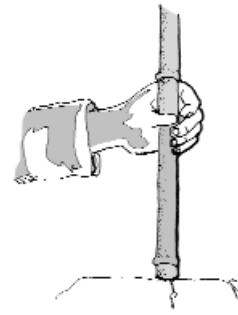

Always cut cane after knots.

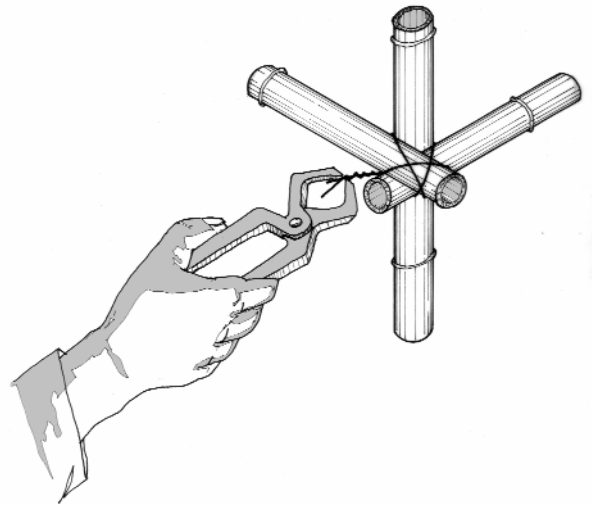

The poles are fastened with a flexible material, such as galvanised wire or treated plant fibre.

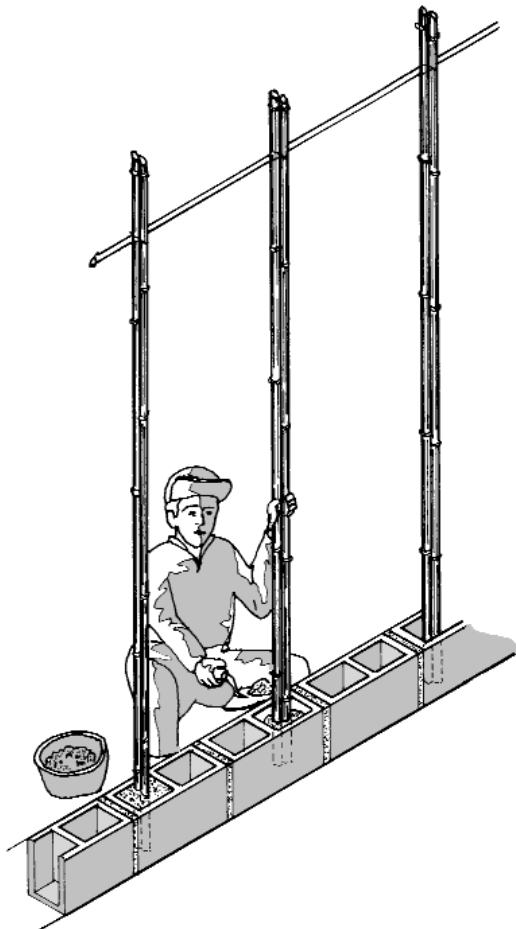

After defining the position of the vertical poles fix them. If you use hollow concrete blocks these can be taken advantage of.

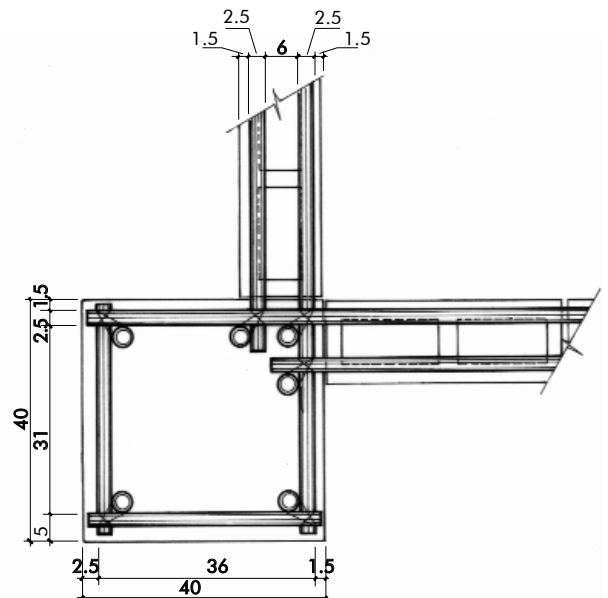

Detail of connection between the corner column and the horizontal canes.

CONSTRUCTION DETAILS

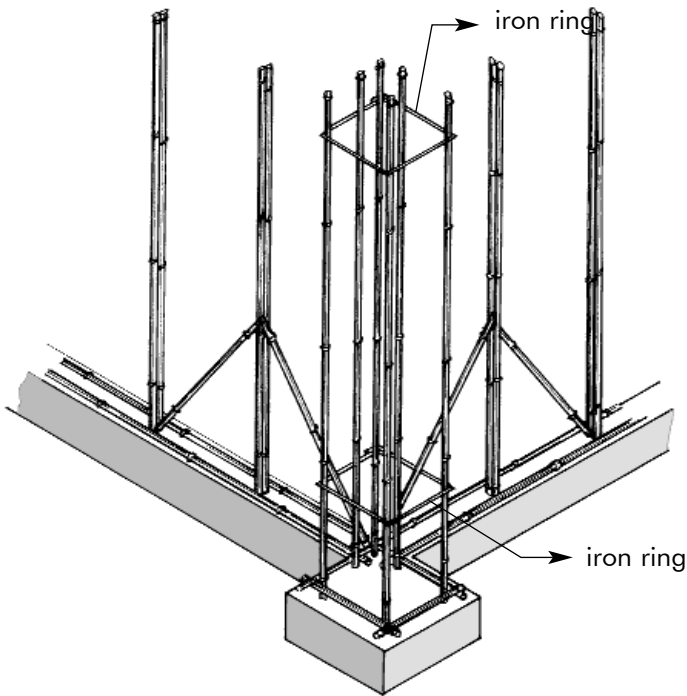

After justalling all the vertical poles, and before fixing the horizontal ones, the fasteners should be fixed.

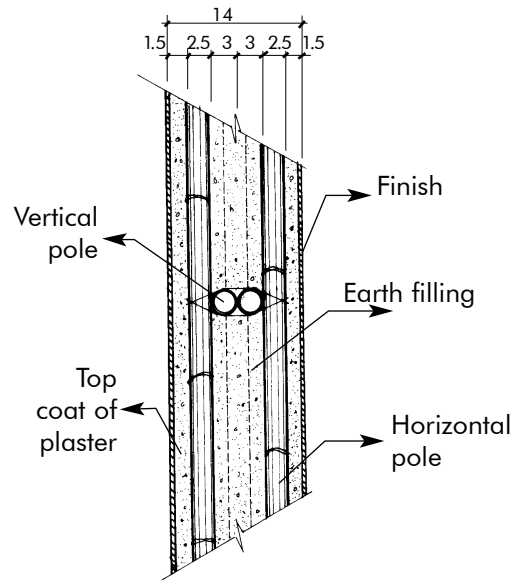

Detail of join between vertical and horizontal poles

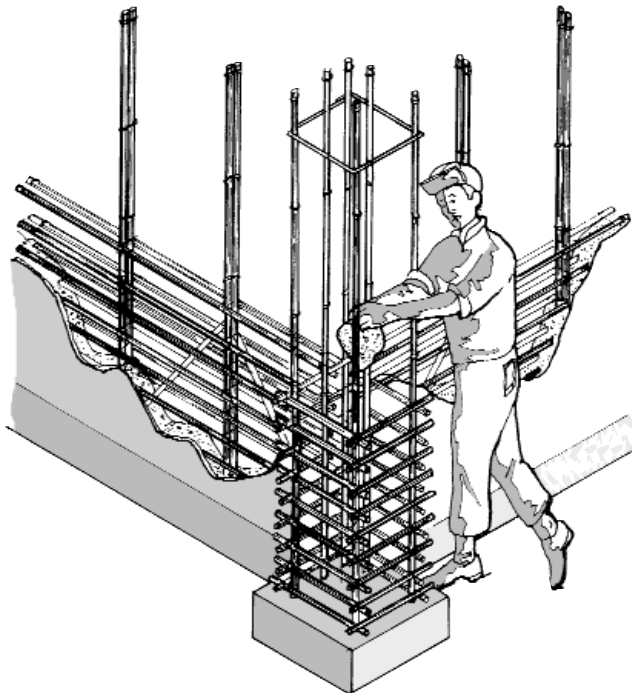

After fitting the horizontal poles at a height of up to 50 cm it is advisable to first fill the columns with wattle and daub mortar followed by the walls. The separation between the horizontal bars should be between 6cm and 8cm.

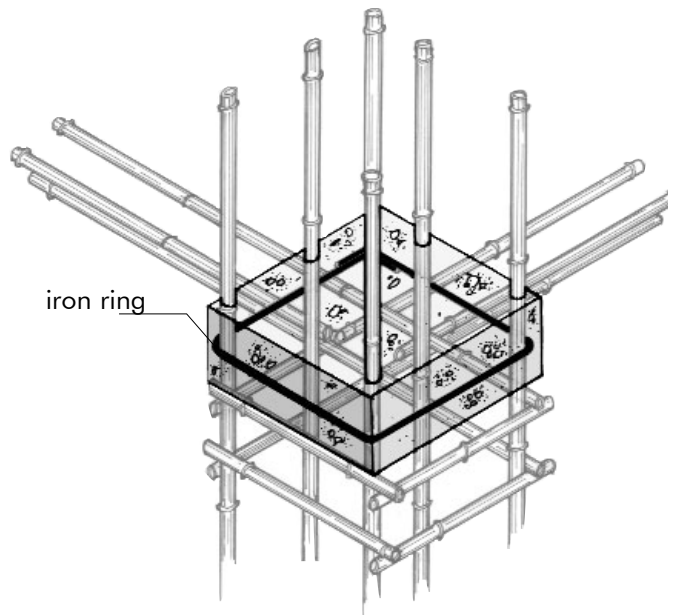

Detail of covering of iron ring (diameter 1/4"), with concrete mortar to make the column rigid.

SEQUENCE FOR THE INSTALLATION OF POLES

